

SB,SBI,SBN 1,3,5,10,15,20,32,45,64,90,120,150 系列 立式多級離心泵

50Hz



公司介紹



臺灣原裝
品質可靠
高效節能

天津斯特尔泵浦科技有限公司是臺灣宏奇泵浦工業有限公司在中國大陸的專業行銷服務機構，總部位於北方經濟中心天津，是宏奇泵浦“STAIRS斯特尔”品牌產品在中國大陸集解決方案，銷售服務，倉儲物流為一體的全面整合型服務機構。為快速，近距離服務于全國各地顧客，我們已經在上海、廣州、南京、長沙、杭州、寧波、濟南、廈門、鄭州、西安、成都、重慶、大連、沈陽、武漢等大中城市設立了銷售服務中心。

宏奇泵浦工業有限公司位于美麗的阿裏山脚下，成立於1981年，是臺灣最大的不銹鋼離心泵專業製造廠，全球第二大深井泵製造廠，長期與德國、日本、美國、意大利等國家的世界頂級泵浦品牌合作研製，在嘉義和臺南的6座工廠面積超過120000m²，設有加工/鑄造，衝壓/焊接，裝配/檢測，電機製造等完整的泵浦制程，每一臺斯特尔泵浦產品95%的零組件皆由宏奇製造和檢測。宏奇泵浦秉持：“持續為顧客提供專業的泵浦製造解決方案和優越的產品品質”的理念，產品行銷全球100多個國家和地區，臺灣宏奇“STAIRS斯特尔”已成為全球十大知名泵浦品牌之一。

“STAIRS斯特尔”泵浦產品主要包括：SBK,CBK浸入式不銹鋼離心泵；SB,SBI,SBN立式不銹鋼離心泵；CB,CBI,HBI,HBNE臥式不銹鋼離心泵；SP不銹鋼深井泵；ST塑膠葉輪導輪深井泵；4,6型油式/屏蔽式潛水馬達；排污泵；熱水循環泵及Aquafos壓力桶等。廣泛的產品使我們提供服務於數控機床，各種工業製冷/清洗/過濾設備，製藥用水/RO反滲透等各種水處理設備，住宅/商業樓宇及冷暖器空調設備供水，電子產品製程以及家用供水設備等。

“提高效率、節約能源”是當代人類的主旋律，也是人類與地球和諧共容的可持續發展戰略。我們願意與有智慧、有遠見的您攜手合作，為了節能，高效的共同目標持續努力，讓人類的明天更加潔淨、美好！





page	產品數據
2	SB,SBI,SBN 性能範圍
3	產品數據
4	產品數據
5	應用範圍
6	型號說明, 電機
7	電機數據, 機械軸封
8	最大運行壓力和入口壓力
9	結構
10	結構
11	結構

page	性能曲綫/技術數據
12	SB, SBI, SBN 1
15	SB, SBI, SBN 3
18	SB, SBI, SBN 5
21	SB, SBI, SBN 10
24	SB, SBI, SBN 15
27	SB, SBI, SBN 20
30	SB, SBI, SBN 32
33	SB, SBI, SBN 45
36	SB, SBI, SBN 64
39	SB, SBI, SBN 90
42	SB, SBI, SBN 120
45	SB, SBI, SBN 150
48	輸送液體說明

性能範圍

Vertical Multistage Centrifugal In-line Pumps



STAIRS PUMPS

SB, SBI, SBN 系列

性能範圍50Hz

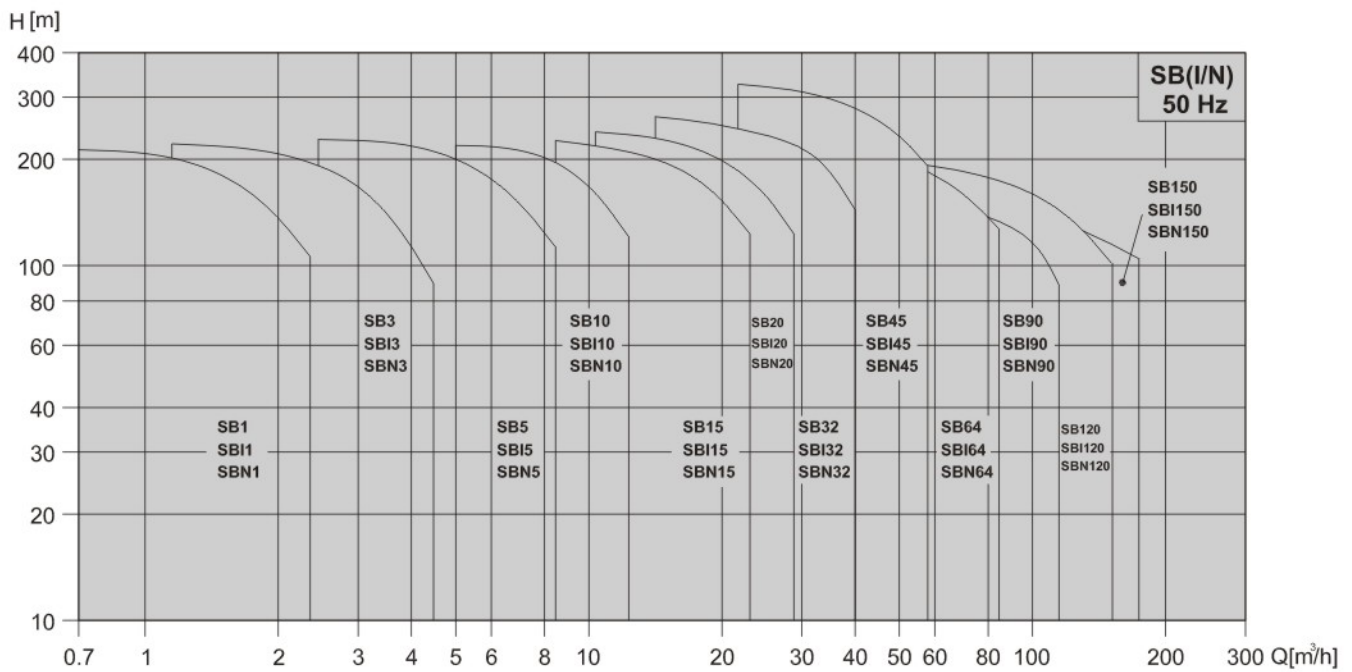

產品數據

Vertical Multistage Centrifugal In-line Pumps



STAIRS PUMPS

產品數據

產品範圍	SB, SBI, SBN					
	1	3	5	10	15	20
50Hz						
標準流量 [m ³ /h]	1	3	5	10	15	20
流量範圍 [m ³ /h]	0.7-2.4	1.2-4.5	2.5-8.5	5-13	8.5-23.5	10.5-29
最大壓力 [bar]	21.5	23	24	21.5	23	24.3
溫度範圍 [°C]	-15 to +120					
電機功率 [kW]	0.37-2.2	0.37-3	0.37-5.5	0.37-7.5	1.1-15	1.1-18.5
規格						
SB: 鑄鐵和 不銹鋼 EN 1.4301/AISI 304	•	•	•	•	•	•
SBI: 不銹鋼 EN 1.4301/AISI 304	•	•	•	•	•	•
SBN: 不銹鋼 EN 1.4401/AISI 316	•	•	•	•	•	•
電機						
供電電壓 1 [~] [V/Hz] (波動範圍 ± 10%)	220-240 V 50 Hz					
供電電壓 3 [~] [V/Hz] (波動範圍 ± 10%)	0.37-7.5 kW 220-240/380-415 V 50 Hz From 11 kW 380-415 V 50 Hz					
絕緣等級	F					
防護等級	IP 55					
環境溫度	50 °C					
SB 管路接口						
法蘭	DN 25/ DN 32	DN 25/ DN 32	DN 25/ DN 32	DN 40	DN 50	DN 50
SBI, SBN 管路接口						
法蘭	DN 25/ DN 32	DN 25/ DN 32	DN 25/ DN 32	DN 40	DN 50	DN 50
卡箍	R 1 ¹ / ₄ DN32	R 1 ¹ / ₄ DN 32	R 1 ¹ / ₄ DN 32	R 2 DN 50	R 2 DN 50	R 2 DN 50
機械軸封						
碳化硅/碳化硅	標準					
密封						
EPDM	標準					
Viton						

* 法蘭標準: 請參考圖紙尺寸

產品數據

Vertical Multistage Centrifugal In-line Pumps



STAIRS PUMPS

產品數據

產品範圍	SB, SBI, SBN					
	32	45	64	90	120	150
50Hz						
標準流量 [m ³ /h]	32	45	64	90	120	150
流量範圍 [m ³ /h]	15-40	22-58	30-85	45-120	60-160	75-180
最大壓力 [bar]	27.5	33	21.8	20	20.4	18.7
溫度範圍 [°C]	-15 to +120					
電機功率 [kW]	1.5-30	3-45	4-45	5.5-45	11-75	11-75
規格						
SB: 鑄鐵和 不銹鋼 EN 1.4301/AISI 304	•	•	•	•	•	•
SBI: 不銹鋼 EN 1.4301/AISI 304	•	•	•	•	•	•
SBN: 不銹鋼 EN 1.4401/AISI 316	•	•	•	•	•	•
電機						
供電電壓 1 [~] [V/Hz] (波動範圍 ± 10%)	220-240 V 50 Hz					
供電電壓 3 [~] [V/Hz] (波動範圍 ± 10%)	0.37-7.5 kW 220-240/380-415 V 50 Hz From 11 kW 380-415 V 50 Hz					
絕緣等級	F					
防護等級	IP 55					
環境溫度	50 °C					
SB 管路接口						
法蘭	DN 65	DN 80	DN100	DN100	DN125	DN125
SBI, SBN 管路接口						
法蘭	DN 65	DN 80	DN100	DN100	DN125	DN125
卡箍	N/A	N/A	N/A	N/A	N/A	N/A
機械軸封						
碳化硅/碳化硅	標準					
密封						
EPDM	標準				0.37kW-45kW	
Viton	標準				55kW-75kW	

* 法蘭標準: 請參考圖紙尺寸

應用範圍

Vertical Multistage Centrifugal In-line Pumps



STAIRS PUMPS

泵浦



SB, SBI, SBN為非自吸立式多級離心泵。管道式泵浦結構設計，通過法蘭或卡箍將泵浦直接安裝在進出口在同一水平綫上且管徑相同的水平管路系統中，這種設計使泵浦的結構和管路更為緊湊。

全系列泵浦配備卡匣式機械軸封，壽命長，易維護。

SB, SBI, SBN 泵浦有不同的規格和多樣的級數以滿足所需流量和壓力。

應用

供水和增壓

高層建築，賓館等增壓
主管網增壓，供水
工業給水增壓

灌溉和農業

溫室
噴灌
漫灌

工業

衝洗和清洗系統
汽車清洗設備
消防系統
流程水系統
機床(冷卻潤滑)

水處理

軟化，電滲析系統
反滲透系統
蒸餾系統
過濾
超濾系統

暖通和空調

鍋爐
感應加熱
熱交換器
制冷設備
冷卻塔和冷凝系統
溫度控制系統

型號說明

Vertical Multistage Centrifugal In-line Pumps



STAIRS PUMPS

型號說明

SB - 10 - 5 - SQQE

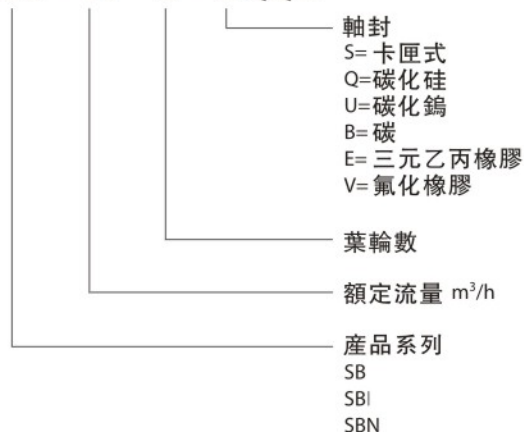

泵浦銘牌信息

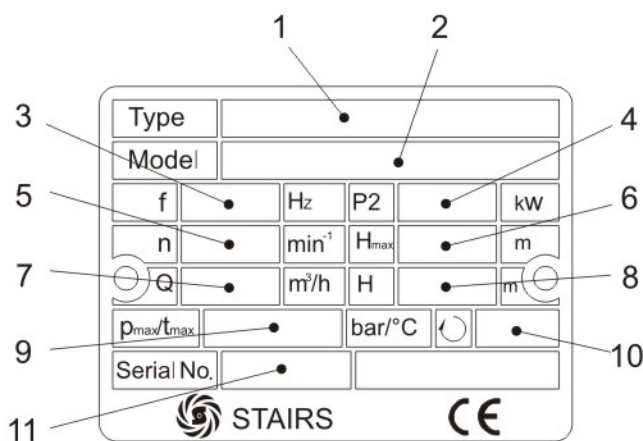

1. 泵浦型號-軸封型式
2. 泵浦型式
3. 頻率
4. 額定功率
5. 電機轉數
6. 最大揚程
7. 標準流量
8. 揚程範圍
9. 最大工作壓力
10. 旋轉方向
11. 生產序列號

電機

- 鼠籠式，全鋁殼體，最大22kW，風冷，二極IEC標準電機
- 電氣數據
 - ◎ 防護等級: IP55
 - ◎ 絕緣等級: F
 - ◎ 標準電壓: P2:0.37-7.5 KW: 3 x 220-240/380-415 V
 - P2: From 11 KW 3 x 380-415 V
- 最高環境溫度: Max. +50°C

電機數據

Vertical Multistage Centrifugal In-line Pumps



STAIRS PUMPS

電機數據

電機規格				額定電流[A]						
HP	kW	Pole	Flange	Frame	3~220 V	3~240 V	3~380 V	3~415 V		
0.5	0.37	2	B14	71A	1.8	1.9	1.0	1.1		
0.75	0.55			71B	2.6	2.7	1.5	1.6		
1.0	0.75			80A	3.4	3.6	2.0	2.1		
1.5	1.1			80B	5.1	5.2	2.9	3.0		
2.0	1.5			90S	6.0	6.2	3.5	3.6		
3.0	2.2			90L	9.5	10.0	5.5	5.8		
4.0	3.0			100L	12.1	12.5	7.0	7.2		
5.5	4.0			112M	14.9	15.0	8.6	8.7		
7.5	5.5			B5			3~380V	3~415V	3~660V	3~690V
10	7.5				132S	12.1	12.0	7.0	6.9	
					132S	16.0	15.3	9.2	8.8	
								3~380 V	3~415 V	
15	11				160M			21.0	19.2	
20	15	160M				28.4	26.0			
25	18.5	160L				34.7	31.8			
30	22	180M				41.1	37.7			
40	30	200L				55.7	51.0			
50	37	200L				68.3	62.5			
60	45	225M				87.2	78.6			
75	55	250M				101.0	92.5			
100	75	280S				134.0	123.0			

機械軸封

標準的卡匣式軸封由碳化硅/碳化硅/EPDM或氟橡膠組成。根據不同的應用選擇適用的軸封和橡膠。不同材質的卡匣式機械軸封可快速更換，不需要特殊的工具或拆解泵浦。

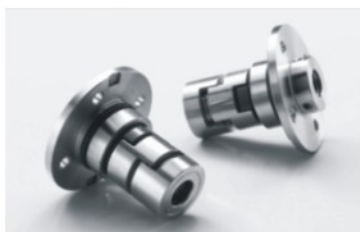

材質列表

Q: 碳化硅	E: 三元乙丙橡膠
U: 碳化鎢	V: 氟橡膠
B: 碳	

軸封型式

型式	SB/SBI/SBN		
	1/3/5/10/15/20 /32/45/64/90	120/150	
		0.5-60HP	75-100HP
機械軸封			
S: O型環式機械軸封	●	●	
B: 橡膠式波紋管			●
QQ	●	●	●
UU	Optional	Optional	
QB	Optional	Optional	
UB	Optional	Optional	
密封			
E	●	●	
V	●	●	●

產品數據

Vertical Multistage Centrifugal In-line Pumps



STAIRS PUMPS

最大運行壓力和入口壓力

50Hz

級數	最大運行壓力	級數	最大入口壓力
SB, SBI, SBN 1			
2-36	25bar	2-36	10bar
SB, SBI, SBN 3			
2-36	25bar	2-29	10bar
		31-36	15bar
SB, SBI, SBN 5			
2-36	25bar	2-16	10bar
		18-36	15bar
SB, SBI, SBN 10			
1-16	16bar	1-6	8bar
17-22	25bar	7-22	10bar
SB, SBI, SBN 15			
1-10	16bar	1-3	8bar
12-17	25bar	4-17	10bar
SB, SBI, SBN 20			
1-10	16bar	1-3	8bar
12-17	25bar	4-17	10bar
SB, SBI, SBN 32			
(1-1)-7	16bar	(1-1)-4	4bar
(8-2)-14	30bar	(5-2)-10	10bar
		(11-2)-14	15bar
SB, SBI, SBN 45			
(1-1)-5	16bar	(1-1)-2	4bar
(6-2)-11	30bar	(3-2)-5	10bar
(12-2)-(13-2)	33bar	(6-2)-(13-2)	15bar
SB, SBI, SBN 64			
(1-1)-5	16bar	(1-1)-(2-2)	4bar
(6-2)-(8-1)	30bar	(2-1)-(4-2)	10bar
		(4-1)-(8-1)	15bar
SB, SBI, SBN 90			
(1-1) - 4	16bar	(1-1) - 1	4bar
(5-2) - 6	30bar	(2-1) - (3-2)	10bar
		3 - 6	15bar
SB, SBI, SBN 120			
1-7	30bar	1-(2-1)	10bar
		2-(5-1)	15bar
		(6-1)-7	20bar
SB, SBI, SBN 150			
(1-1)-6	30bar	(1-1)-1	10bar
		(2-1)-(4-2)	15bar
		(5-2)-6	20bar

*入口壓力+泵浦的閉閥壓力<最大運行壓力

結構

Vertical Multistage Centrifugal In-line Pumps



STAIRS PUMPS

結構

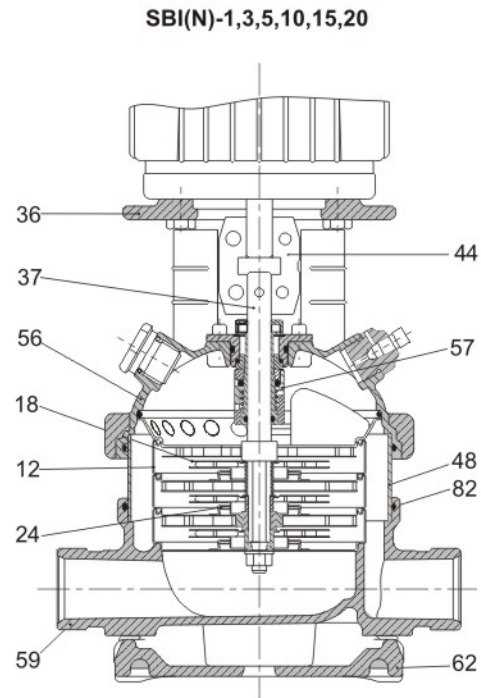
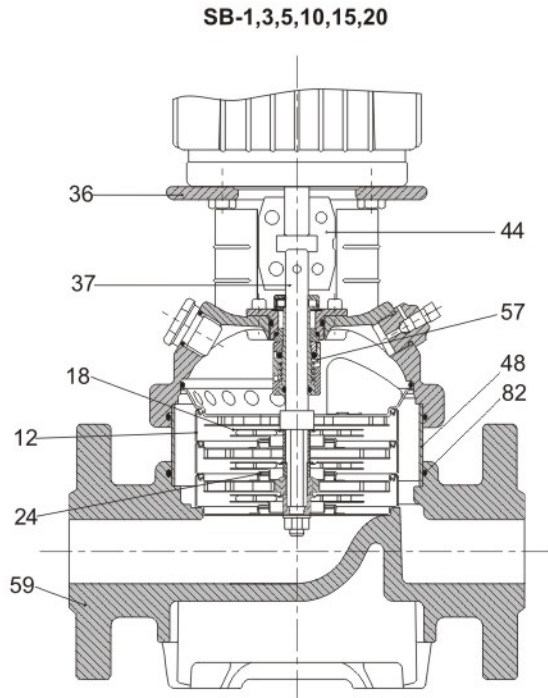

Pos.	名稱	材質	SB 1,3,5,10,15,20		SBI 1,3,5,10,15,20		SBN 1,3,5,10,15,20	
			標準		標準		標準	
			Europe	USA	Europe	USA	Europe	USA
36	泵頭	鑄鐵	EN-GJL-200	ASTM 25B	EN-GJS-450-10	ASTM 65-45-12	EN-GJS-450-10	ASTM 65-45-12
56	泵頭殼	不銹鋼	N/A		1.4301	AISI 304	1.4401	AISI 316
18	葉輪	不銹鋼	1.4301	AISI 304	1.4301	AISI 304	1.4401	AISI 316
37	軸	不銹鋼	1.4057	AISI 431	1.4057	AISI 431	1.4401	AISI 316
48	外筒	不銹鋼	1.4301	AISI 304	1.4301	AISI 304	1.4401	AISI 316
82	外筒O型環	EPDM						
12	腔體	不銹鋼	1.4301	AISI 304	1.4301	AISI 304	1.4401	AISI 316
24	頸環	PTFE						
59	基座	鑄鐵	EN-GJL-200	ASTM 25B	N/A			
	基座	不銹鋼	N/A		1.4301	AISI 304	1.4401	AISI 316
62	基板	鑄鐵	N/A		EN-GJL-200	ASTM 25B	EN-GJL-200	ASTM 25B
44	聯軸器	Fe-Cu-C	SINT C11	MPIF FC0525	SINT C11	MPIF FC0525	SINT C11	MPIF FC0525
57	機械軸封	卡匣式						

結構

Vertical Multistage Centrifugal In-line Pumps



STAIRS PUMPS

結構

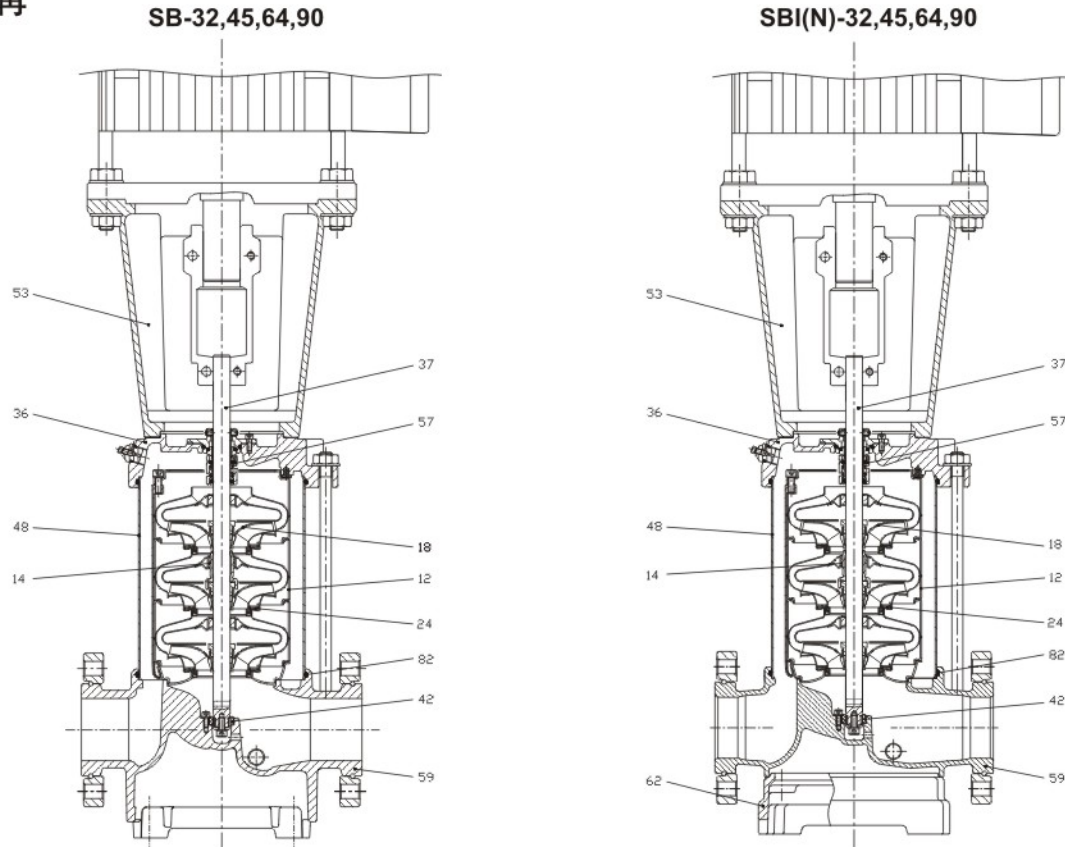

Pos.	名稱	材質	SB 32, 45, 64, 90		SBI 32, 45, 64, 90		SBN 32, 45, 64, 90	
			標準		標準		標準	
			Europe	USA	Europe	USA	Europe	USA
36	泵頭	鑄鐵	EN-GJL-250	ASTM 35B				
		不銹鋼			1.4301	AISI 304	1.4401	AISI 316
53	電機支架	鑄鐵	EN-GJL-250	ASTM 35B	EN-GJL-250	ASTM 35B	EN-GJL-250	ASTM 35B
18	葉輪	不銹鋼	1.4301	AISI 304	1.4301	AISI 304	1.4401	AISI 316
37	軸	不銹鋼	1.4057	AISI 431	1.4057	AISI 431	1.4401	AISI 316
48	外筒	不銹鋼	1.4301	AISI 304	1.4301	AISI 304	1.4401	AISI 316
82	外筒O型環	EPDM						
12	腔體	不銹鋼	1.4301	AISI 304	1.4301	AISI 304	1.4401	AISI 316
24	頸環	Carbon Fiber + POB + PTFE						
59	基座	鑄鐵	EN-GJL-250	ASTM 35B	N/A			
	基座	不銹鋼	N/A		1.4301	AISI 304	1.4401	AISI 316
62	基板	鑄鐵	N/A		EN-GJL-250	ASTM 35B	EN-GJL-250	ASTM 35B
57	機械軸封	卡匣式						
14	軸承環		Bronze				POB+Graphite+PTFE	
42	底部軸承環	碳化鎢/ 碳化鎢						

結構

Vertical Multistage Centrifugal In-line Pumps



STAIRS PUMPS

結構

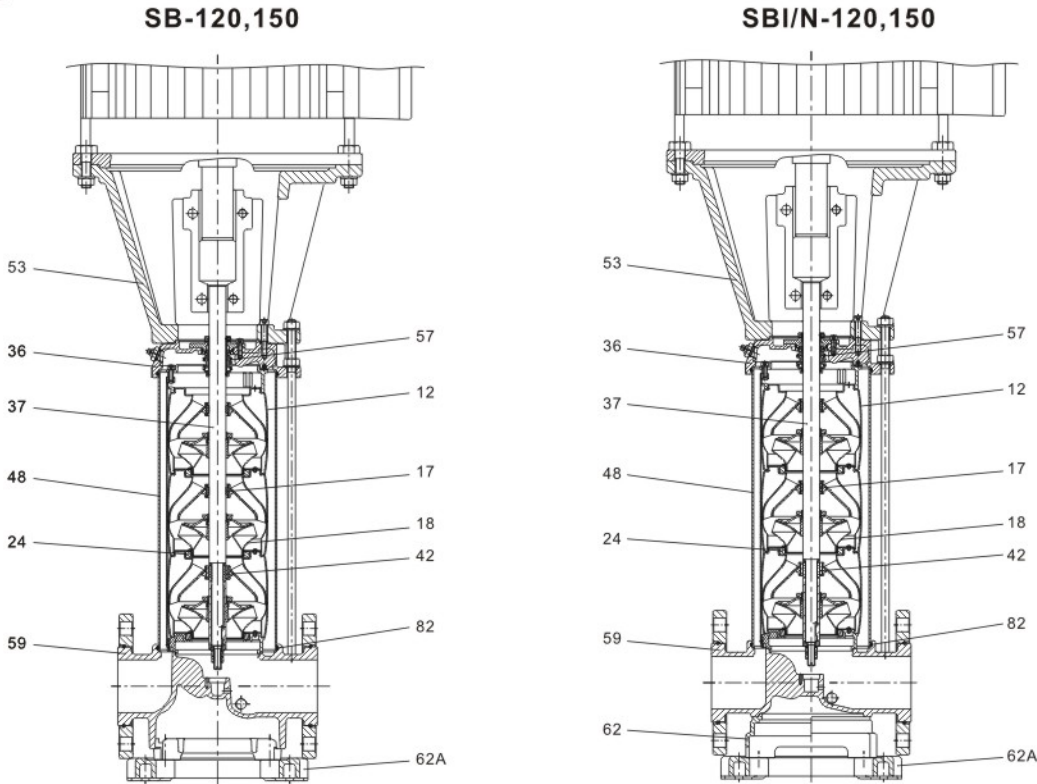

Pos.	名稱	材質	SB 120, 150		SBI 120, 150		SBN 120, 150	
			標準		標準		標準	
			Europe	USA	Europe	USA	Europe	USA
36	泵頭	鑄鐵	EN-GJL-250	ASTM 35B	N/A			
		不銹鋼	N/A		1.4301	AISI 304	1.4401	AISI 316
53	電機支架 (15HP~60HP)	鑄鐵	EN-GJL-250	ASTM 35B	EN-GJL-250	ASTM 35B	EN-GJL-250	ASTM 35B
	電機支架 (75HP~100HP)	鑄鐵	EN-GJS-450-10	ASTM 65-45-12	EN-GJS-450-10	ASTM 65-45-12	EN-GJS-450-10	ASTM 65-45-12
17	軸承環	PTFE						
18	葉輪	不銹鋼	1.4301	AISI 304	1.4301	AISI 304	1.4401	AISI 316
37	軸	不銹鋼	1.4057	AISI 431	1.4057	AISI 431	1.4401	AISI 316
48	外筒	不銹鋼	1.4301	AISI 304	1.4301	AISI 304	1.4401	AISI 316
82	外筒O型環	EPDM						
12	腔體	不銹鋼	1.4301	AISI 304	1.4301	AISI 304	1.4401	AISI 316
24	頸環	PTFE						
59	基座	鑄鐵	EN-GJL-250	ASTM 35B	N/A			
		不銹鋼	N/A		1.4301	AISI 304	1.4401	AISI 316
62	基板	鑄鐵	N/A		EN-GJS-450-10	ASTM 65-45-12	EN-GJS-450-10	ASTM 65-45-12
62A	基板	鑄鐵	EN-GJS-450-10	ASTM 65-45-12	EN-GJS-450-10	ASTM 65-45-12	EN-GJS-450-10	ASTM 65-45-12
57	機械軸封	卡匣式						
42	底部軸承環	碳化硅/碳化硅						

性能曲綫

Vertical Multistage Centrifugal In-line Pumps



STAIRS PUMPS

SB, SBI, SBN 1

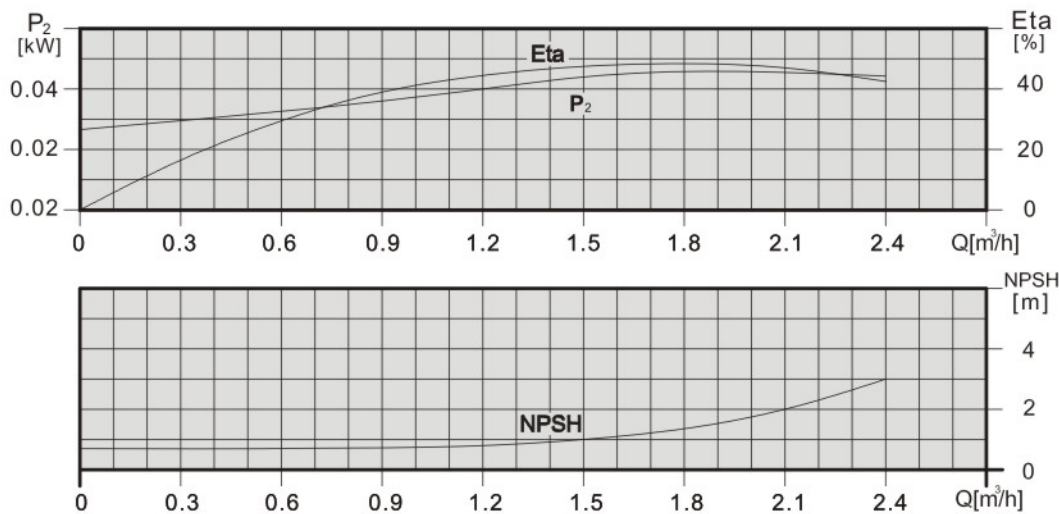
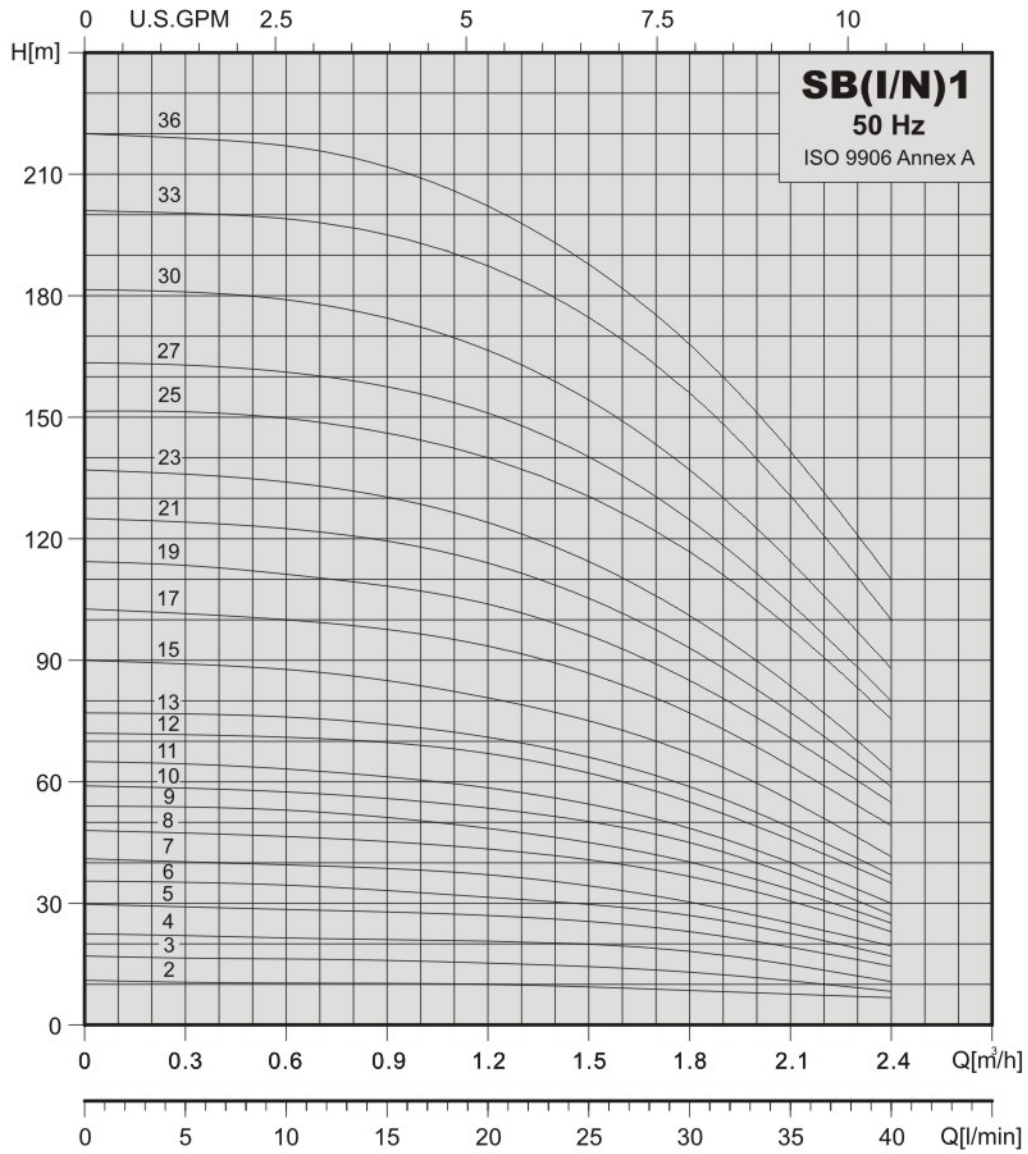



尺寸和重量-SB1

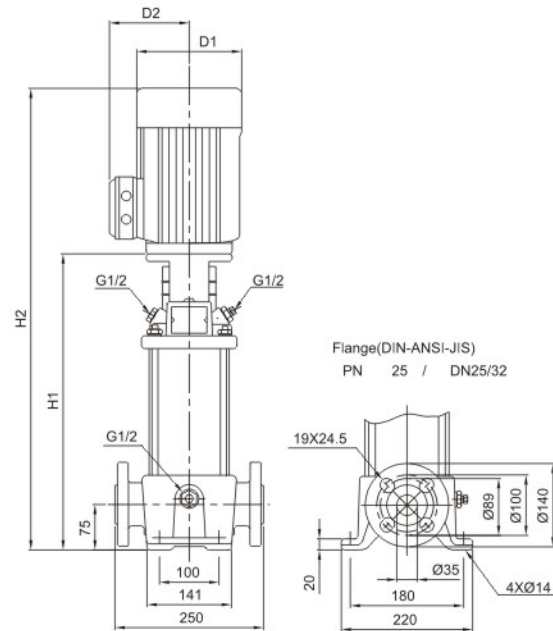

泵浦型號	電機	SB				
		尺寸[mm]				淨重 [kg]
	P ₂ [kW]	DIN flange		D1	D2	
H1	H2					
SB1-2	0.37	279	474	141	115	23.4
SB1-3	0.37	279	474	141	115	23.4
SB1-4	0.37	297	492	141	115	23.8
SB1-5	0.37	315	510	141	115	24.2
SB1-6	0.37	333	528	141	115	24.5
SB1-7	0.37	351	546	141	115	24.9
SB1-8	0.55	369	564	141	115	25.8
SB1-9	0.55	387	582	141	115	26.1
SB1-10	0.55	405	600	141	115	26.5
SB1-11	0.55	423	618	141	115	26.9
SB1-12	0.75	447	682	141	115	29.4
SB1-13	0.75	465	700	141	115	29.8
SB1-15	0.75	501	736	141	115	30.5
SB1-17	1.1	537	772	141	115	32.3
SB1-19	1.1	573	808	141	115	33.1
SB1-21	1.1	609	844	141	115	33.8
SB1-23	1.1	645	880	141	115	34.6
SB1-25	1.5	697	988	177	141	44.0
SB1-27	1.5	733	1024	177	141	44.8
SB1-30	1.5	787	1078	177	141	45.9
SB1-33	2.2	841	1132	177	141	49.9
SB1-36	2.2	895	1186	177	141	51.0



尺寸和重量-SBI,SBN1

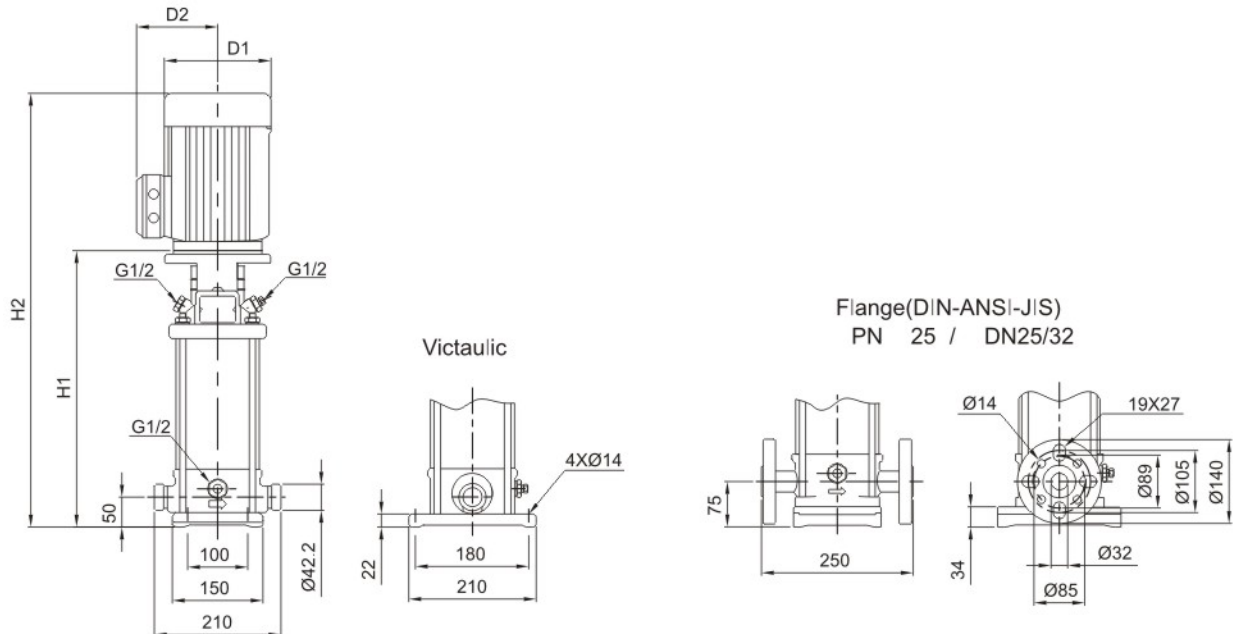

泵浦型號	電機 P ₂ [kW]	SBI, SBN							
		尺寸[mm]						淨重[kg]	
		Victaulic		DIN flange		D1	D2	Victaulic	DIN flange
H1	H2	H1	H2						
SBI,SBN1-2	0.37	257	452	282	477	141	115	19.3	20.2
SBI,SBN1-3	0.37	257	452	282	477	141	115	19.3	20.3
SBI,SBN1-4	0.37	275	470	300	495	141	115	19.7	20.6
SBI,SBN1-5	0.37	293	488	318	513	141	115	20.1	21.0
SBI,SBN1-6	0.37	311	506	336	531	141	115	20.4	21.4
SBI,SBN1-7	0.37	329	524	354	549	141	115	20.8	21.7
SBI,SBN1-8	0.55	347	542	372	567	141	115	21.7	22.6
SBI,SBN1-9	0.55	365	560	390	585	141	115	22.0	23.0
SBI,SBN1-10	0.55	383	578	408	603	141	115	22.4	23.3
SBI,SBN1-11	0.55	401	596	426	621	141	115	22.8	23.7
SBI,SBN1-12	0.75	425	660	450	685	141	115	25.2	26.1
SBI,SBN1-13	0.75	443	678	468	703	141	115	25.6	26.5
SBI,SBN1-15	0.75	479	714	504	739	141	115	26.3	27.2
SBI,SBN1-17	1.1	515	750	540	775	141	115	28.1	29.1
SBI,SBN1-19	1.1	551	786	576	811	141	115	28.8	29.8
SBI,SBN1-21	1.1	587	822	612	847	141	115	29.6	30.6
SBI,SBN1-23	1.1	623	858	648	883	141	115	30.4	31.3
SBI,SBN1-25	1.5	675	966	700	991	177	141	39.8	40.8
SBI,SBN1-27	1.5	711	1002	736	1027	177	141	40.6	41.5
SBI,SBN1-30	1.5	765	1056	790	1081	177	141	41.7	42.6
SBI,SBN1-33	2.2	819	1110	844	1135	177	141	45.6	46.6
SBI,SBN1-36	2.2	873	1164	898	1189	177	141	46.7	47.7

性能曲綫

Vertical Multistage Centrifugal In-line Pumps



STAIRS PUMPS

SB, SBI, SBN 3

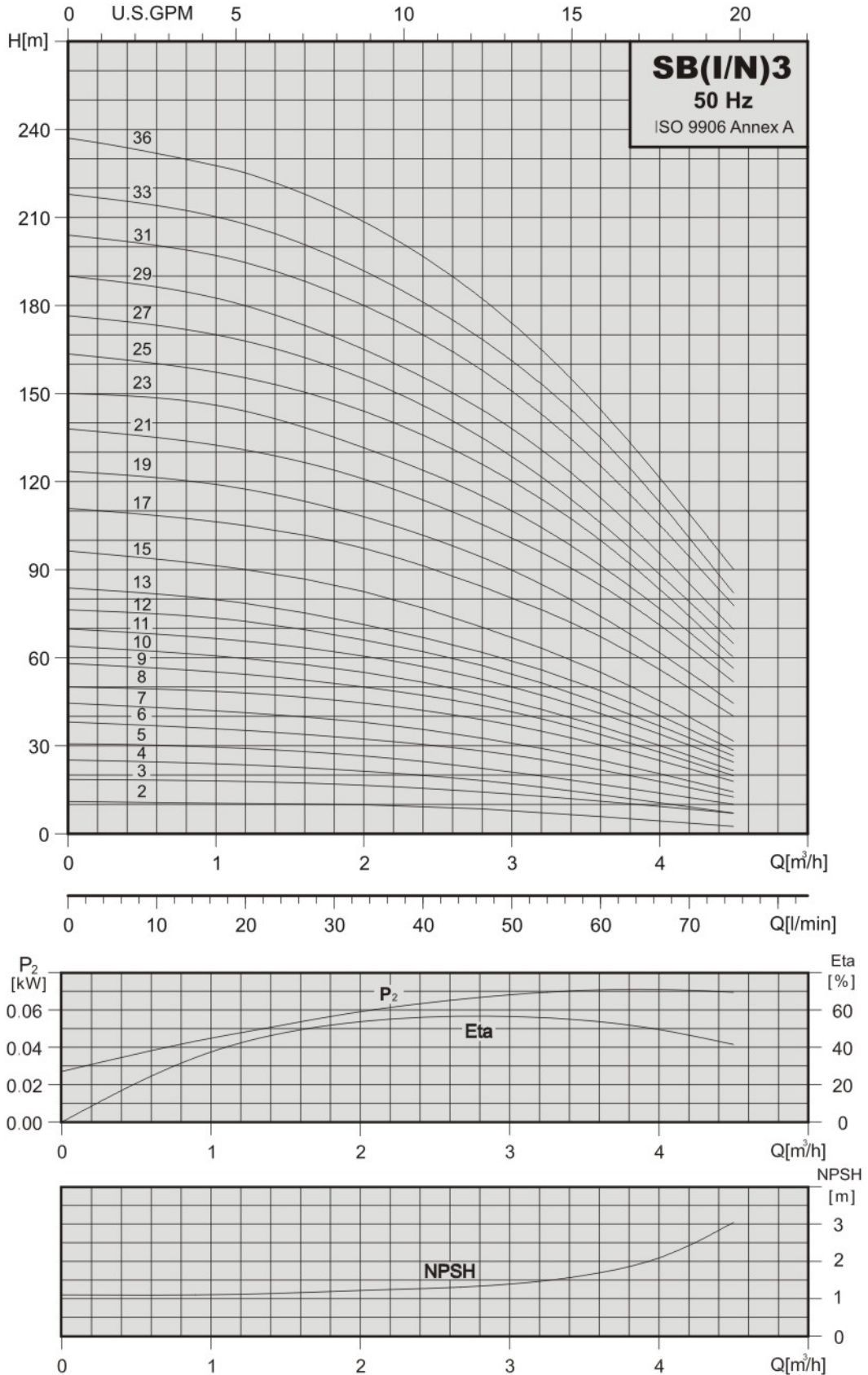



尺寸和重量-SB3

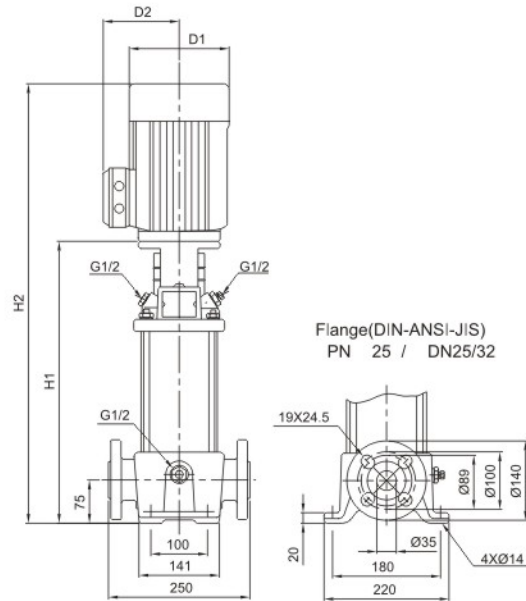

泵浦型號	電機 P ₂ [kW]	SB				淨重 [kg] DIN flange
		尺寸[mm]		D1	D2	
		H1	H2			
SB 3-2	0.37	279	474	141	115	23.4
SB 3-3	0.37	279	474	141	115	23.4
SB 3-4	0.37	297	492	141	115	23.8
SB 3-5	0.37	315	510	141	115	24.2
SB 3-6	0.55	333	528	141	115	25.0
SB 3-7	0.55	351	546	141	115	25.4
SB 3-8	0.75	375	610	141	115	27.9
SB 3-9	0.75	393	628	141	115	28.3
SB 3-10	0.75	411	646	141	115	28.7
SB 3-11	1.1	429	664	141	115	30.2
SB 3-12	1.1	447	682	141	115	30.5
SB 3-13	1.1	465	700	141	115	30.9
SB 3-15	1.1	501	736	141	141	31.6
SB 3-17	1.5	553	844	177	141	41.0
SB 3-19	1.5	589	880	177	141	41.8
SB 3-21	2.2	625	916	177	141	45.3
SB 3-23	2.2	661	952	177	141	46.1
SB 3-25	2.2	697	988	177	141	46.8
SB 3-27	2.2	733	1024	177	141	47.6
SB 3-29	2.2	769	1060	177	141	48.3
SB 3-31	3	809	1125	197	147	56.6
SB 3-33	3	845	1161	197	147	57.4
SB 3-36	3	899	1215	197	147	58.5

技術數據

Vertical Multistage Centrifugal In-line Pumps



STAIRS PUMPS

尺寸和重量-SBI,SBN3

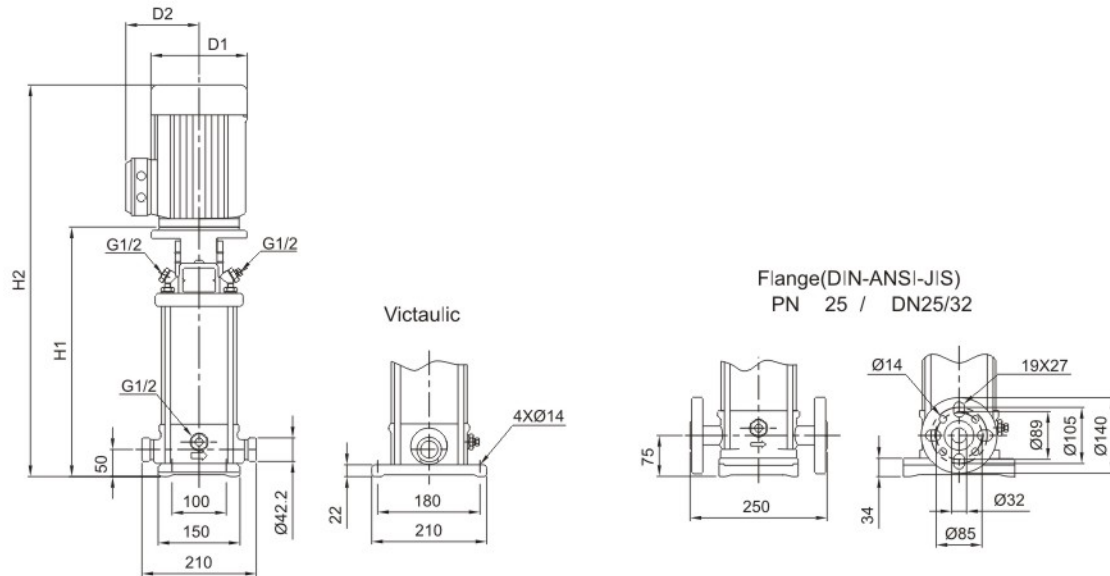

泵浦型號	電機 P ₂ [kW]	SBI, SBN							
		尺寸[mm]						淨重[kg]	
		Victaulic		DIN flange		D1	D2	Victaulic	DIN flange
H1	H2	H1	H2						
SBI,SBN3-2	0.37	257	452	282	477	141	115	19.3	20.2
SBI,SBN3-3	0.37	257	452	282	477	141	115	19.3	20.3
SBI,SBN3-4	0.37	275	470	300	495	141	115	19.7	20.6
SBI,SBN3-5	0.37	293	488	318	513	141	115	20.1	21.0
SBI,SBN3-6	0.55	311	506	336	531	141	115	20.9	21.9
SBI,SBN3-7	0.55	329	524	354	549	141	115	21.3	22.2
SBI,SBN3-8	0.75	353	588	378	613	141	115	23.7	24.6
SBI,SBN3-9	0.75	371	606	396	631	141	115	24.0	25.0
SBI,SBN3-10	0.75	389	624	414	649	141	115	24.4	25.4
SBI,SBN3-11	1.1	407	642	432	667	141	115	25.9	26.9
SBI,SBN3-12	1.1	425	660	450	685	141	115	26.3	27.2
SBI,SBN3-13	1.1	443	678	468	703	141	115	26.7	27.6
SBI,SBN3-15	1.1	479	714	504	739	141	115	27.4	28.3
SBI,SBN3-17	1.5	531	822	556	847	177	141	36.9	37.8
SBI,SBN3-19	1.5	567	858	592	883	177	141	37.6	38.5
SBI,SBN3-21	2.2	603	894	628	919	177	141	41.2	42.1
SBI,SBN3-23	2.2	639	930	664	955	177	141	41.9	42.9
SBI,SBN3-25	2.2	675	966	700	991	177	141	42.6	43.6
SBI,SBN3-27	2.2	711	1002	736	1027	177	141	43.4	44.3
SBI,SBN3-29	2.2	747	1038	772	1063	177	141	44.1	45.1
SBI,SBN3-31	3	787	1103	812	1128	197	147	52.0	53.0
SBI,SBN3-33	3	823	1139	848	1164	197	147	52.8	53.7
SBI,SBN3-36	3	877	1193	902	1218	197	147	53.9	54.8

性能曲綫

Vertical Multistage Centrifugal In-line Pumps



STAIRS PUMPS

SB, SBI, SBN 5

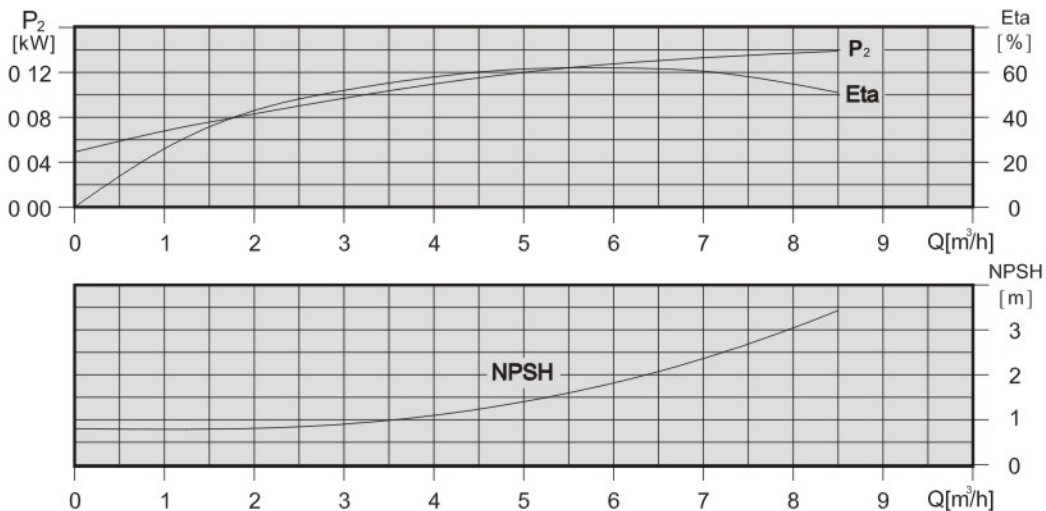
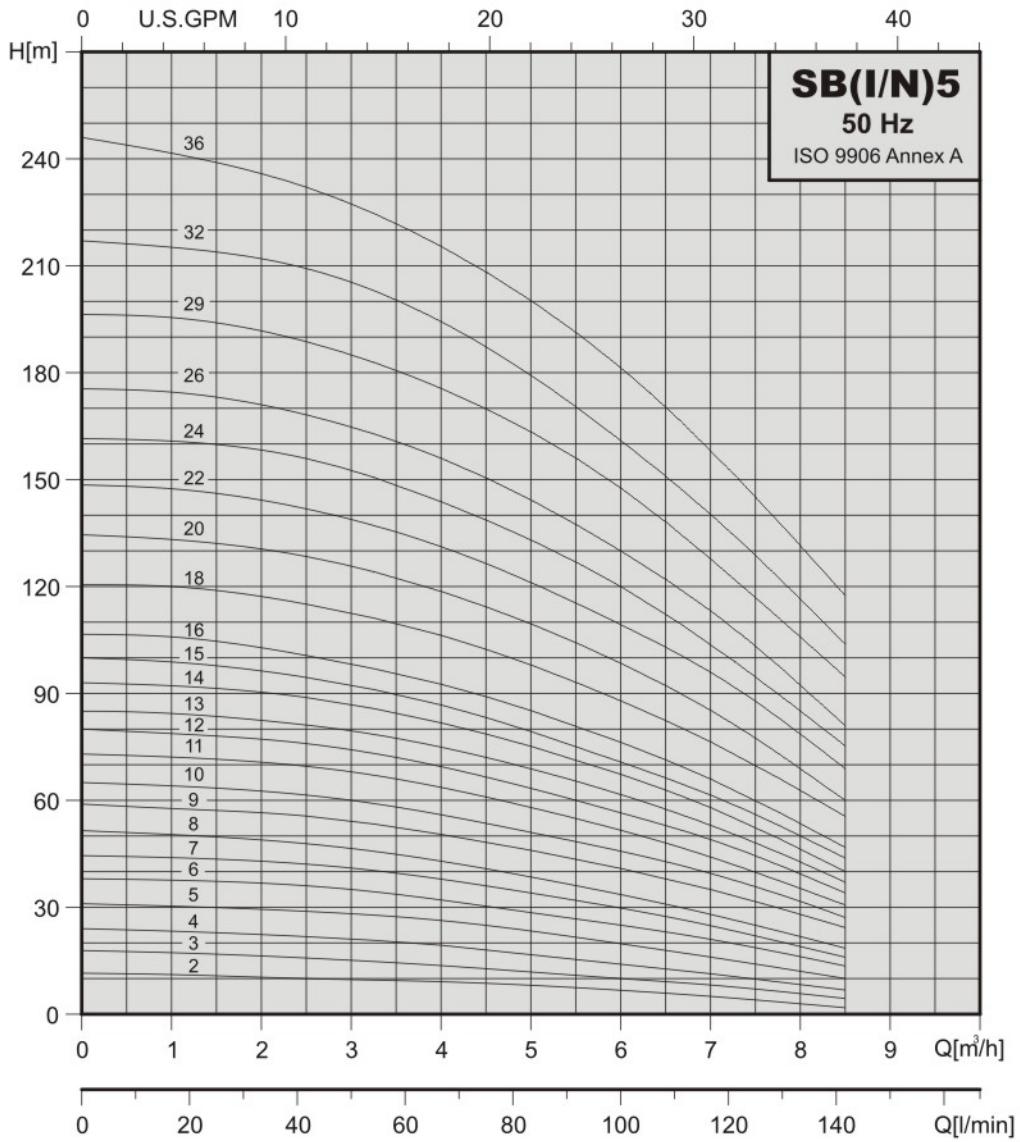

技術數據

Vertical Multistage Centrifugal In-line Pumps



STAIRS PUMPS

尺寸和重量-SB5

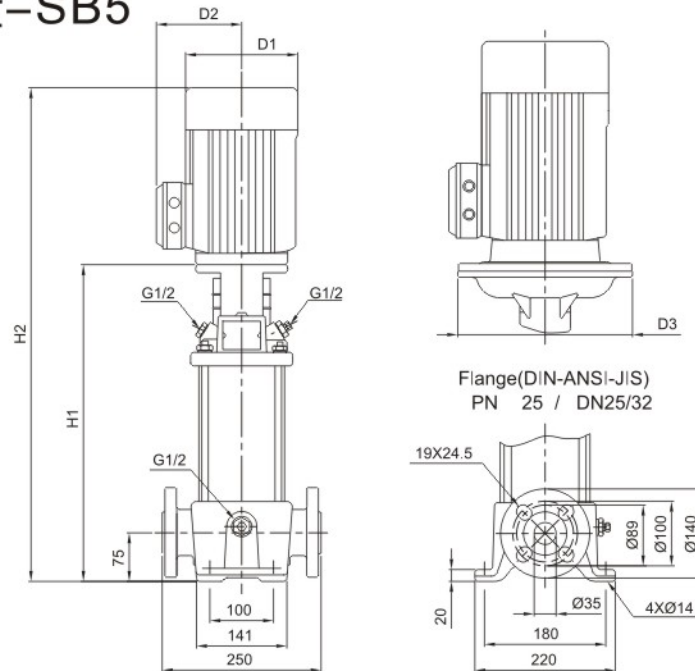

泵浦型號	電機 P ₂ [kW]	SB					淨重 [kg] DIN flange
		尺寸[mm]		D1	D2	D3	
		H1	H2				
SB 5-2	0.37	279	474	141	115	—	23.3
SB 5-3	0.55	306	501	141	115	—	24.2
SB 5-4	0.55	333	528	141	115	—	24.8
SB 5-5	0.75	366	601	141	115	—	27.4
SB 5-6	1.1	393	628	141	115	—	29.1
SB 5-7	1.1	420	655	141	115	—	29.6
SB 5-8	1.1	447	682	141	115	—	30.1
SB 5-9	1.5	490	781	177	141	—	39.3
SB 5-10	1.5	517	808	177	141	—	39.9
SB 5-11	2.2	544	835	177	141	—	43.2
SB 5-12	2.2	571	862	177	141	—	43.7
SB 5-13	2.2	598	889	177	141	—	44.2
SB 5-14	2.2	625	916	177	141	—	44.8
SB 5-15	2.2	652	943	177	141	—	45.2
SB 5-16	2.2	679	970	177	141	—	45.8
SB 5-18	3	737	1053	197	147	—	54.3
SB 5-20	3	791	1107	197	147	—	55.5
SB 5-22	4	845	1171	220	161	—	59.8
SB 5-24	4	899	1225	220	161	—	60.8
SB 5-26	4	953	1279	220	161	—	62.7
SB 5-29	4	1034	1360	220	161	—	64.6
SB 5-32	5.5	1145	1507	235	197	300	90.1
SB 5-36	5.5	1253	1615	235	197	300	92.6



尺寸和重量-SBI,SBN5

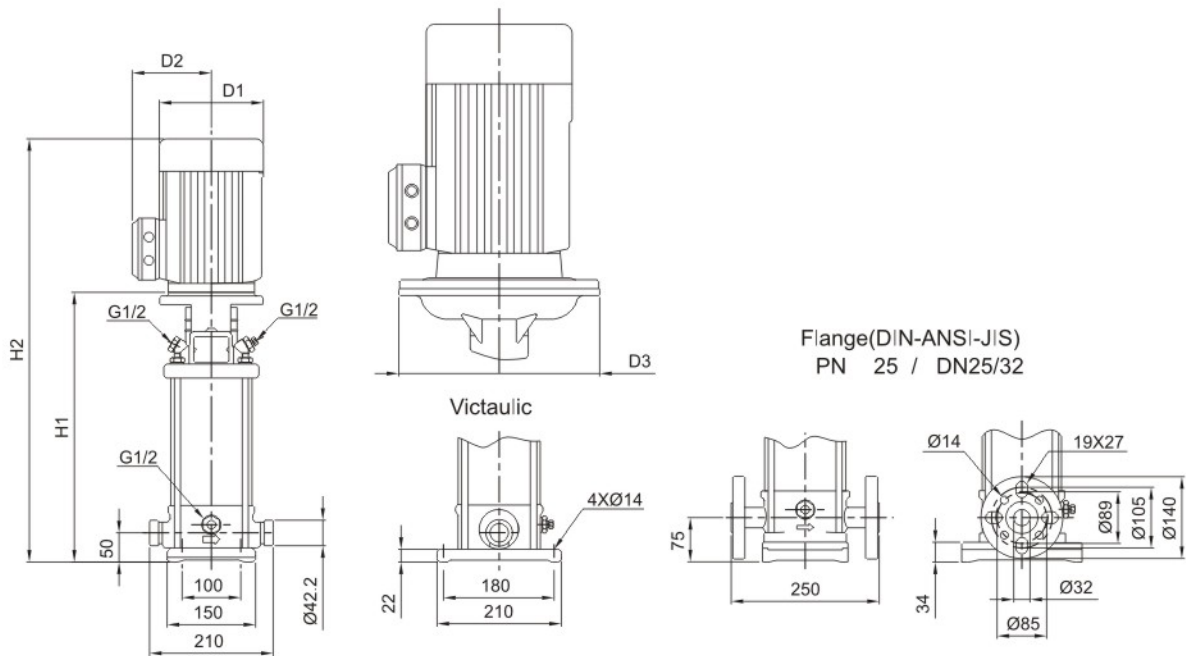

泵浦型號	電機 P ₂ [kW]	SBI, SBN								
		尺寸[mm]						淨重[kg]		
		Victaulic		DIN flange		D1	D2	D3	Victaulic	DIN flange
H1	H2	H1	H2							
SBI,SBN5-2	0.37	257	452	282	477	141	115	—	19.2	20.1
SBI,SBN5-3	0.55	284	479	309	504	141	115	—	20.3	21.2
SBI,SBN5-4	0.55	311	506	336	531	141	115	—	20.8	21.8
SBI,SBN5-5	0.75	344	579	369	604	141	115	—	23.4	24.3
SBI,SBN5-6	1.1	371	606	396	631	141	115	—	25.1	26.0
SBI,SBN5-7	1.1	398	633	423	658	141	115	—	25.6	26.5
SBI,SBN5-8	1.1	425	660	450	685	141	115	—	26.1	27.1
SBI,SBN5-9	1.5	468	759	493	784	177	141	—	35.4	36.4
SBI,SBN5-10	1.5	495	786	520	811	177	141	—	36.0	36.9
SBI,SBN5-11	2.2	522	813	547	838	177	141	—	39.3	40.3
SBI,SBN5-12	2.2	549	840	574	865	177	141	—	39.9	40.8
SBI,SBN5-13	2.2	576	867	601	892	177	141	—	40.4	41.4
SBI,SBN5-14	2.2	603	894	628	919	177	141	—	41.0	41.9
SBI,SBN5-15	2.2	630	921	655	946	177	141	—	41.5	42.5
SBI,SBN5-16	2.2	657	948	682	973	177	141	—	42.1	43.0
SBI,SBN5-18	3	715	1031	740	1056	197	147	—	50.3	51.3
SBI,SBN5-20	3	769	1085	794	1110	197	147	—	51.6	52.5
SBI,SBN5-22	4	823	1149	848	1174	220	161	—	55.8	56.8
SBI,SBN5-24	4	877	1203	902	1228	220	161	—	56.9	57.8
SBI,SBN5-26	4	931	1257	956	1282	220	161	—	58.0	58.9
SBI,SBN5-29	4	1012	1338	1037	1363	220	161	—	59.7	60.6
SBI,SBN5-32	5.5	1123	1485	1148	1510	235	197	300	84.9	85.8
SBI,SBN5-36	5.5	1231	1593	1256	1618	235	197	300	87.1	88.1

性能曲綫

Vertical Multistage Centrifugal In-line Pumps



STAIRS PUMPS

SB, SBI, SBN 10

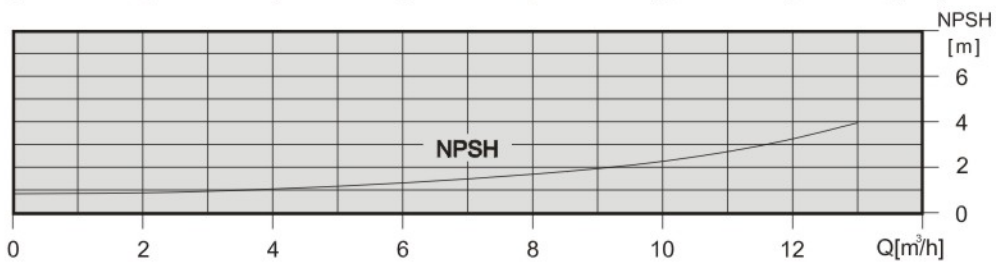
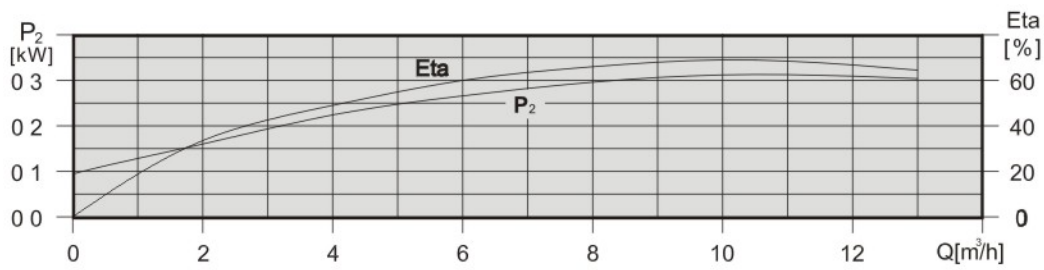
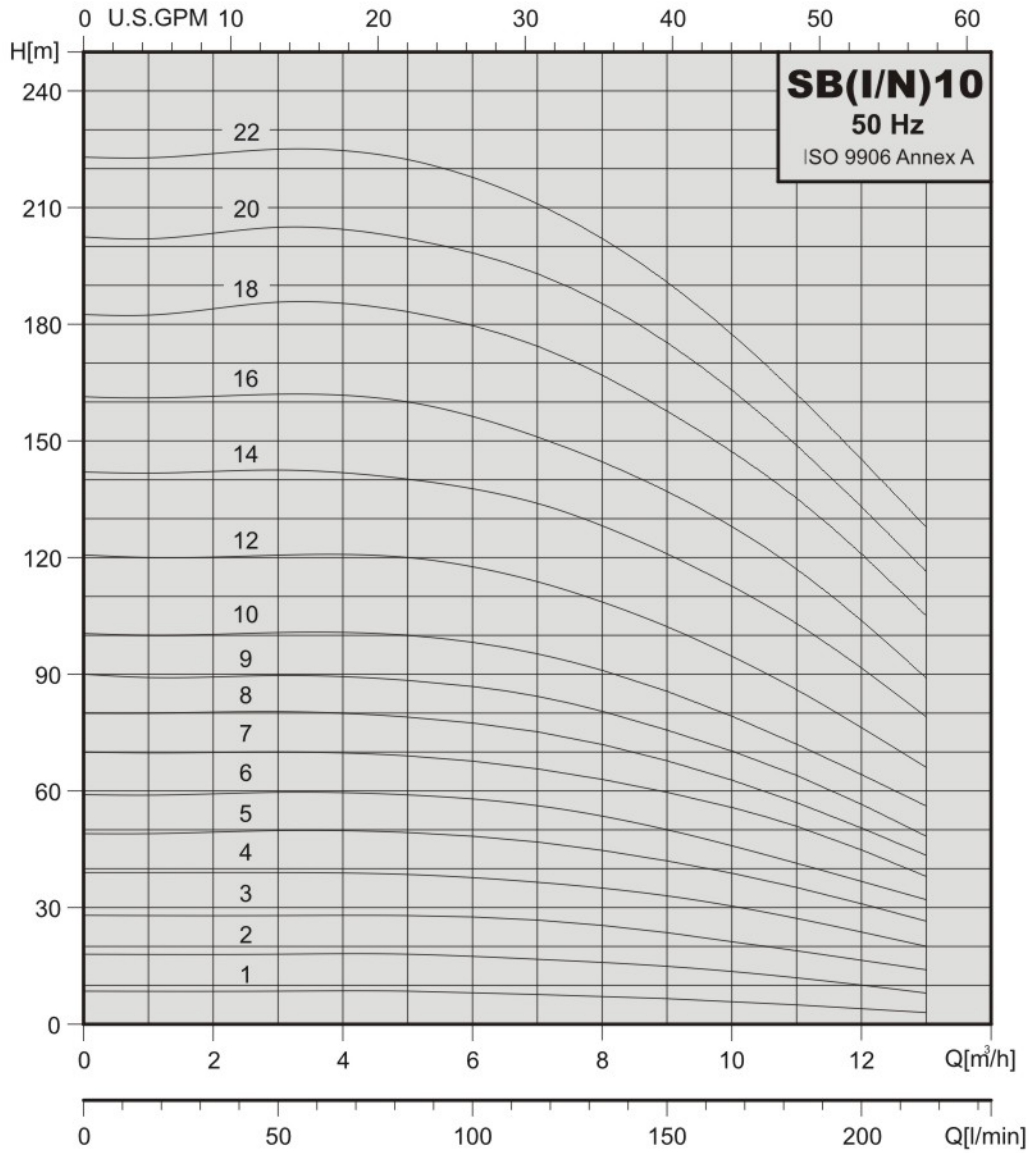



尺寸和重量-SB10

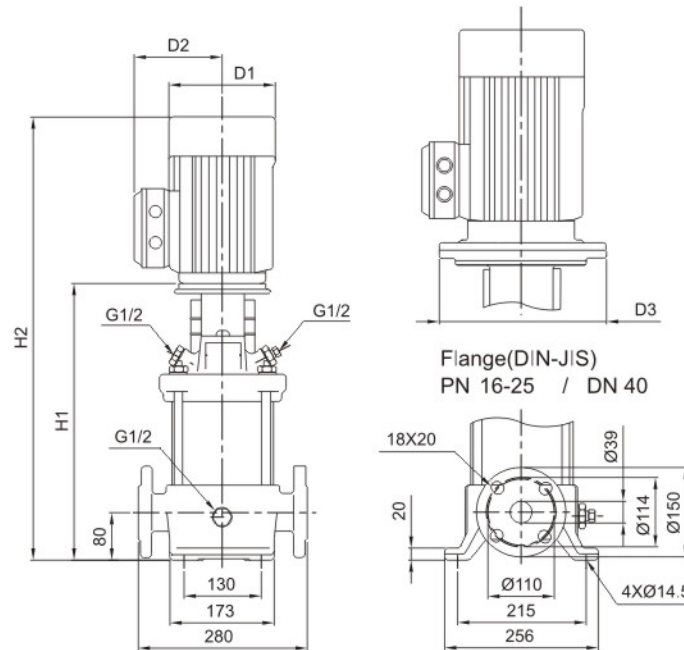

泵浦型號	電機	SB					淨重 [kg]
		尺寸[mm]					
	P ₂ [kW]	DIN flange		D1	D2	D3	DIN flange
		H1	H2				
SB 10-1	0.37	343	538	141	115	—	35.9
SB 10-2	0.75	347	582	141	115	—	38.2
SB 10-3	1.1	377	612	141	115	—	40.3
SB 10-4	1.5	423	714	177	141	—	50.1
SB 10-5	2.2	453	744	177	141	—	53.9
SB 10-6	2.2	483	774	177	141	—	55.0
SB 10-7	3	518	834	197	147	—	63.8
SB 10-8	3	548	864	197	147	—	64.9
SB 10-9	3	578	894	197	147	—	65.9
SB 10-10	4	608	934	220	161	—	70.3
SB 10-12	4	668	994	220	161	—	72.4
SB 10-14	5.5	760	1122	235	197	300	104.1
SB 10-16	5.5	820	1182	235	197	300	106.2
SB 10-18	7.5	880	1278	235	197	300	113.6
SB 10-20	7.5	940	1338	235	197	300	116.7
SB 10-22	7.5	1000	1398	235	197	300	118.8

技術數據

Vertical Multistage Centrifugal In-line Pumps



STAIRS PUMPS

尺寸和重量-SBI,SBN 10

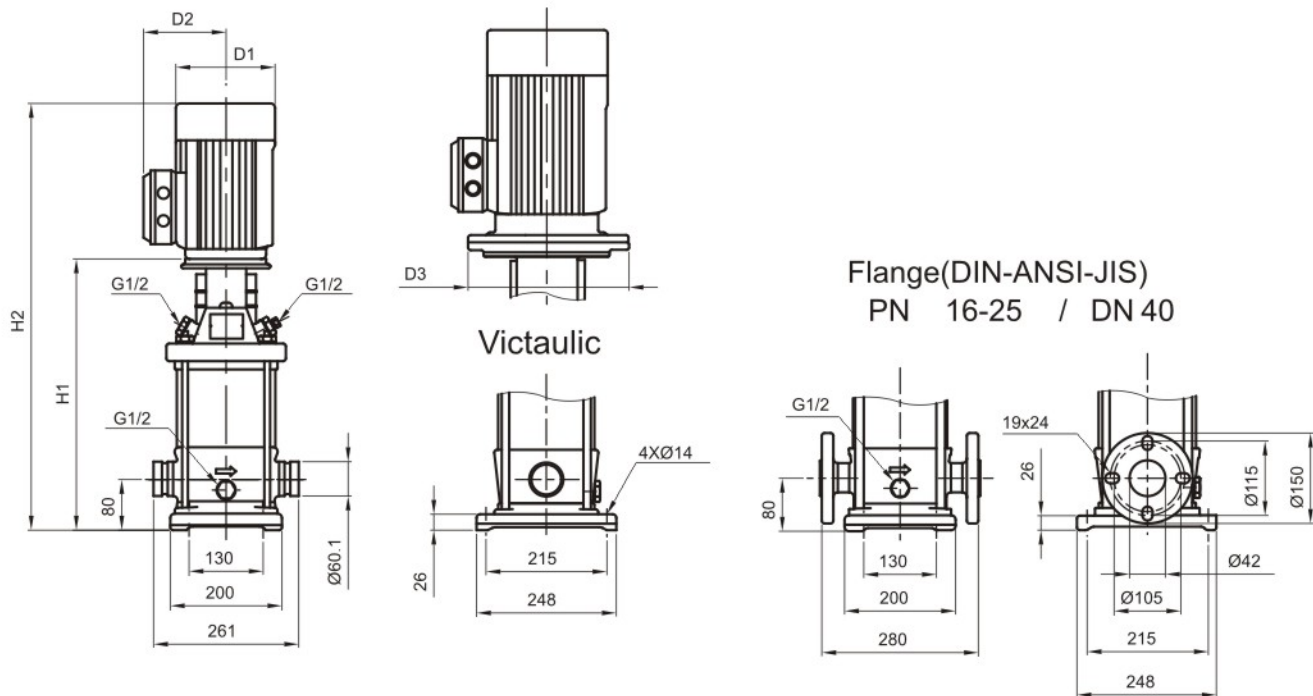

泵浦型號	電機 P ₂ [kW]	SBI, SBN								
		尺寸[mm]						淨重[kg]		
		Victaulic		DIN flange		D1	D2	D3	Victaulic	DIN flange
H1	H2	H1	H2							
SBI,SBN10-1	0.37	353	548	353	548	141	115	—	31.6	31.4
SBI,SBN10-2	0.75	357	592	357	592	141	115	—	34.3	34.2
SBI,SBN10-3	1.1	387	622	387	622	141	115	—	36.4	36.3
SBI,SBN10-4	1.5	433	724	433	724	177	141	—	46.1	46.0
SBI,SBN10-5	2.2	463	754	463	754	177	141	—	50.0	49.8
SBI,SBN10-6	2.2	493	784	493	784	177	141	—	51.0	50.8
SBI,SBN10-7	3	528	844	528	844	197	147	—	59.1	58.9
SBI,SBN10-8	3	558	874	558	874	197	147	—	60.1	60.0
SBI,SBN10-9	3	588	904	588	904	197	147	—	61.1	61.0
SBI,SBN10-10	4	618	944	618	944	220	161	—	65.6	65.4
SBI,SBN10-12	4	678	1004	678	1004	220	161	—	67.6	67.5
SBI,SBN10-14	5.5	770	1132	770	1132	235	197	300	100.4	100.3
SBI,SBN10-16	5.5	830	1192	830	1192	235	197	300	102.5	102.4
SBI,SBN10-18	7.5	890	1288	890	1288	235	197	300	110.9	110.8
SBI,SBN10-20	7.5	950	1348	950	1348	235	197	300	113.0	112.8
SBI,SBN10-22	7.5	1010	1408	1010	1408	235	197	300	115.1	114.9

性能曲綫

Vertical Multistage Centrifugal In-line Pumps



STAIRS PUMPS

SB, SBI, SBN 15

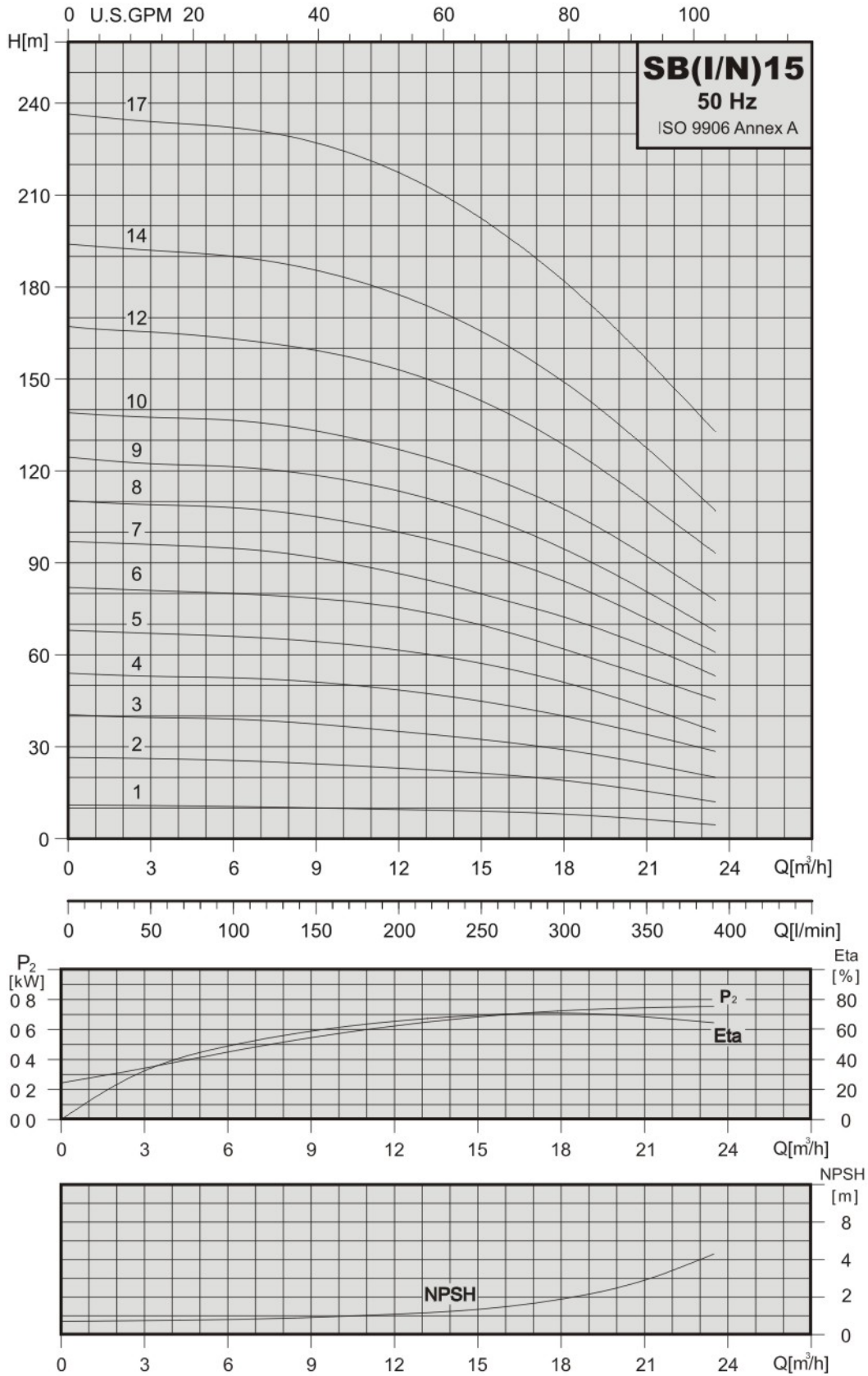

技術數據

Vertical Multistage Centrifugal In-line Pumps



STAIRS PUMPS

尺寸和重量-SB 15

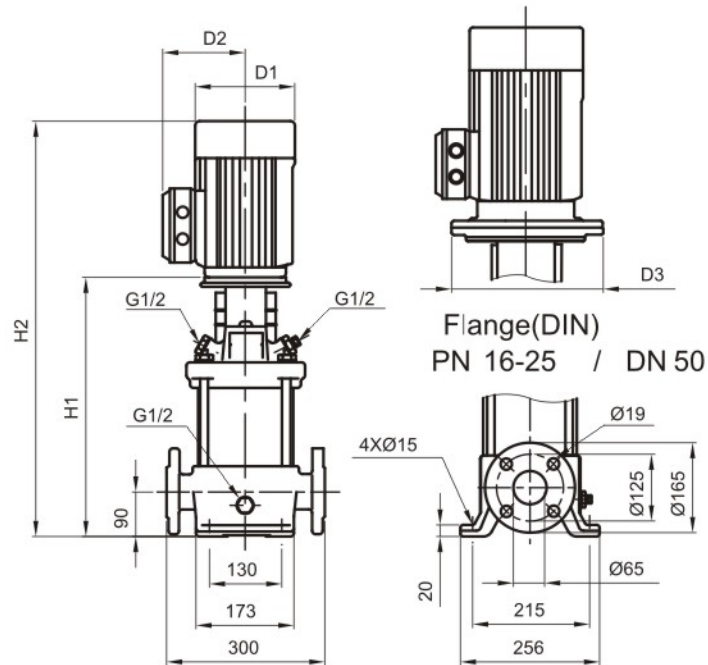

泵浦型號	電機	SB					淨重 [kg]
		尺寸[mm]					
	P ₂ [kW]	DIN flange		D1	D2	D3	DIN flange
		H1	H2				
SB 15-1	1.1	400	635	141	115	—	43.8
SB 15-2	2.2	415	706	177	141	—	55.7
SB 15-3	3	465	781	197	147	—	64.9
SB 15-4	4	510	836	220	161	—	69.7
SB 15-5	4	555	881	220	161	—	71.2
SB 15-6	5.5	632	994	235	197	300	102.3
SB 15-7	5.5	677	1039	235	197	300	103.8
SB 15-8	7.5	722	1120	235	197	300	111.8
SB 15-9	7.5	767	1165	235	197	300	113.3
SB 15-10	11	889	1394	318	154	300	150.0
SB 15-12	11	979	1484	318	154	300	153.0
SB 15-14	11	1069	1574	318	154	300	156.3
SB 15-17	15	1204	1714	318	154	300	171.5



尺寸和重量-SBI,SBN 15

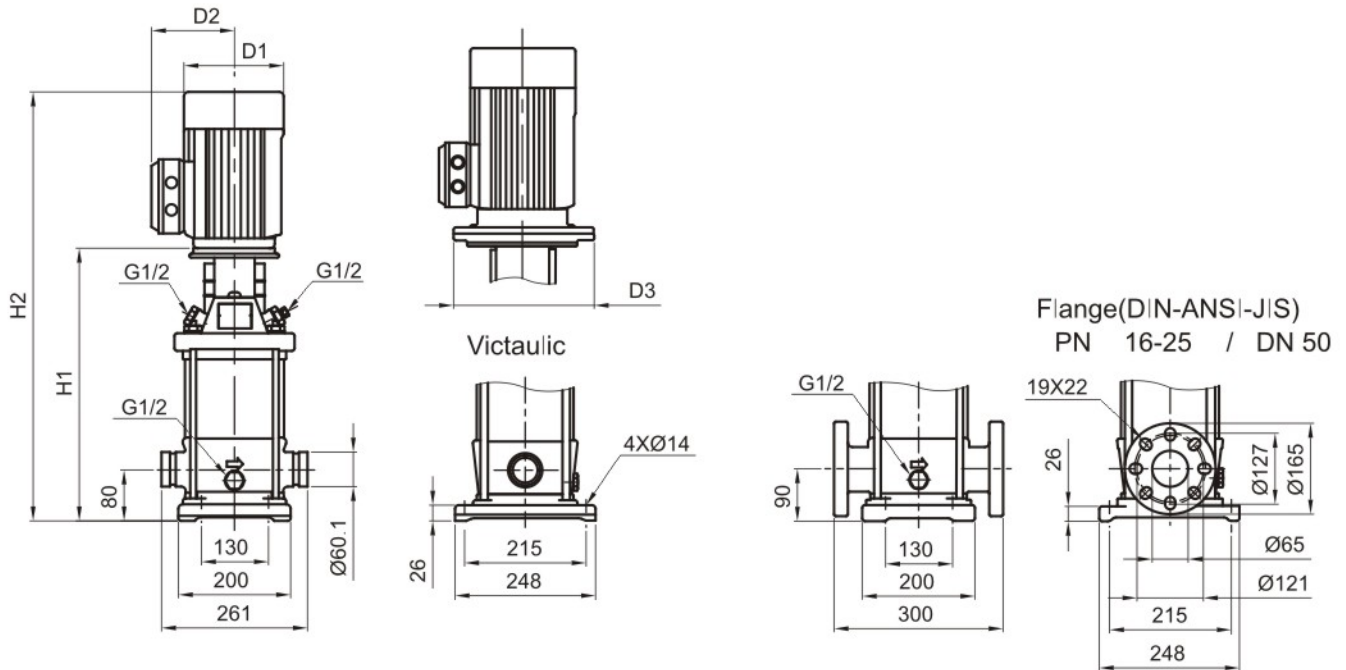

泵浦型號	電機	SBI, SBN								
		尺寸[mm]							淨重[kg]	
		Victaulic		DIN flange		D1	D2	D3	Victaulic	DIN flange
H1	H2	H1	H2							
SBI,SBN15-1	1.1	387	622	397	632	141	115	—	36.0	36.6
SBI,SBN15-2	2.2	403	694	413	704	177	141	—	47.7	48.3
SBI,SBN15-3	3	453	769	463	779	197	147	—	56.1	56.7
SBI,SBN15-4	4	498	824	508	834	220	161	—	61.0	61.6
SBI,SBN15-5	4	543	869	553	879	220	161	—	62.4	63.0
SBI,SBN15-6	5.5	620	982	630	992	235	197	300	94.6	95.3
SBI,SBN15-7	5.5	665	1027	675	1037	235	197	300	96.1	96.7
SBI,SBN15-8	7.5	710	1108	720	1118	235	197	300	104.1	104.7
SBI,SBN15-9	7.5	755	1153	765	1163	235	197	300	105.6	106.2
SBI,SBN15-10	11	877	1382	887	1392	318	154	350	142.7	143.3
SBI,SBN15-12	11	967	1472	977	1482	318	154	350	145.5	146.2
SBI,SBN15-14	11	1057	1562	1067	1572	318	154	350	148.5	149.1
SBI,SBN15-17	15	1192	1702	1202	1712	318	154	350	162.9	163.5

性能曲綫

Vertical Multistage Centrifugal In-line Pumps



STAIRS PUMPS

SB, SBI, SBN 20

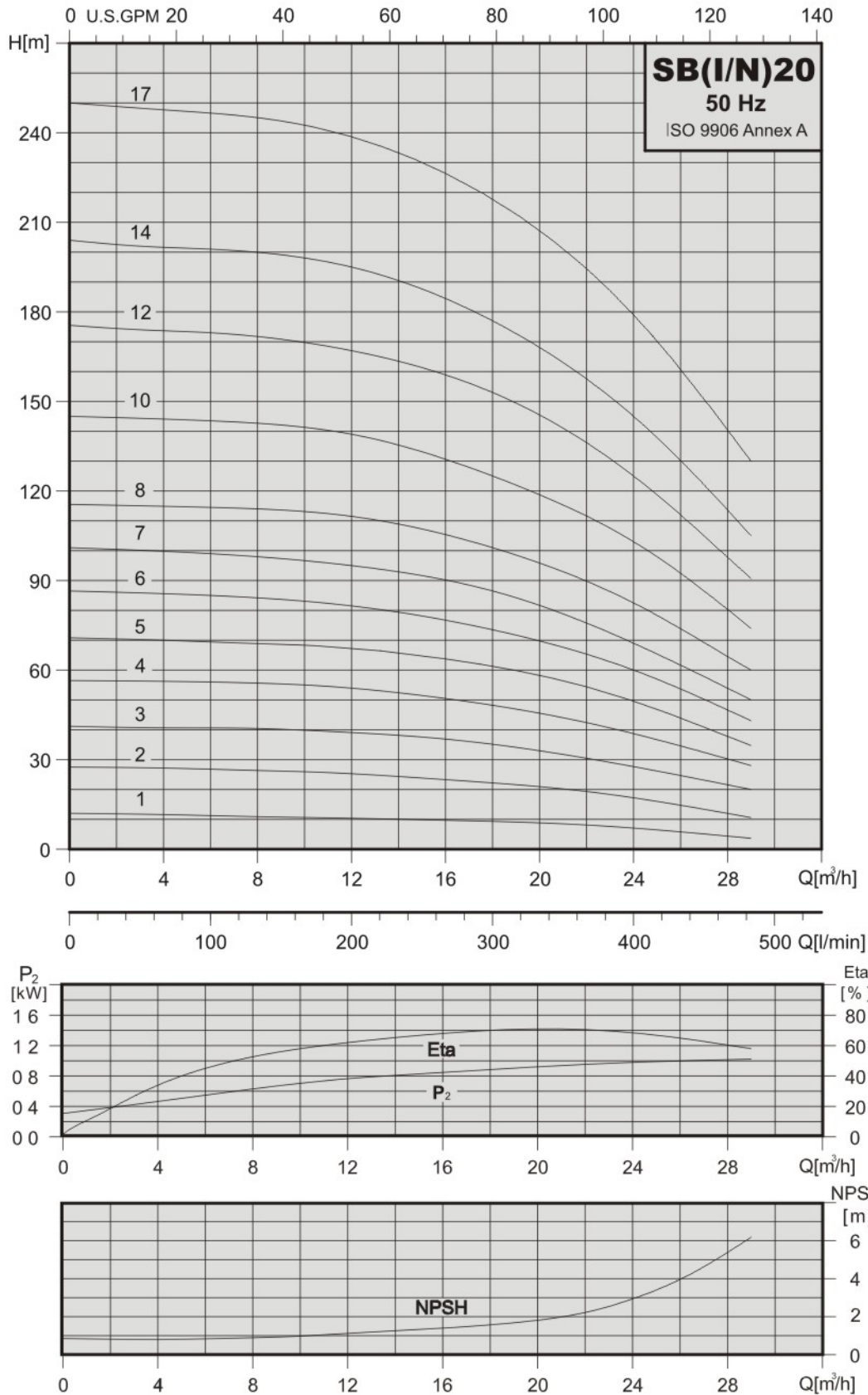



尺寸和重量-SB20

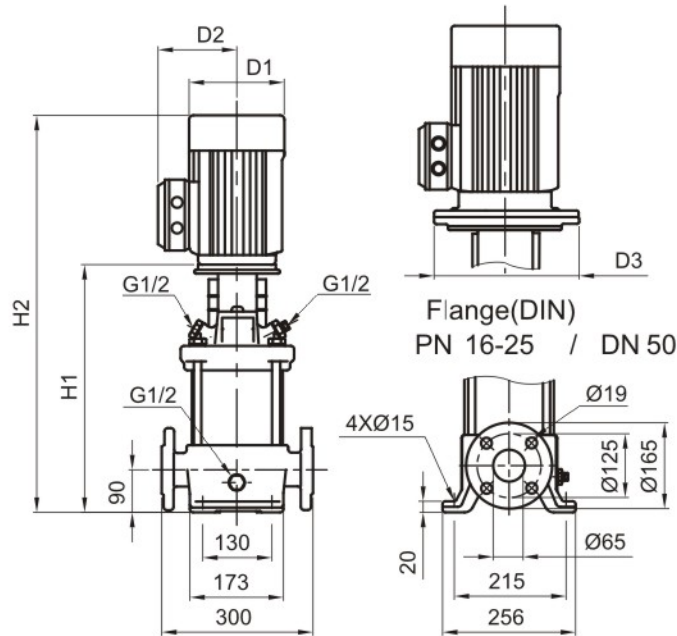

泵浦型號	電機 P ₂ [kW]	SB					淨重 [kg] DIN flange
		DIN flange		尺寸[mm]			
		H1	H2	D1	D2	D3	
SB 20-1	1.1	400	636	141	115	—	43.9
SB 20-2	2.2	415	708	177	141	—	55.7
SB 20-3	4	465	795	220	161	—	68.3
SB 20-4	5.5	542	910	235	197	300	99.4
SB 20-5	5.5	587	955	235	197	300	100.8
SB 20-6	7.5	632	1038	235	197	300	108.6
SB 20-7	7.5	677	1083	235	197	300	110.1
SB 20-8	11	799	1315	318	245	350	147.1
SB 20-10	11	889	1405	318	245	350	150.0
SB 20-12	15	979	1504	318	245	350	163.1
SB 20-14	15	1069	1594	318	245	350	166.0
SB 20-17	18.5	1204	1773	318	245	350	195.4

技術數據

Vertical Multistage Centrifugal In-line Pumps



STAIRS PUMPS

尺寸和重量-SBI,SBN 20

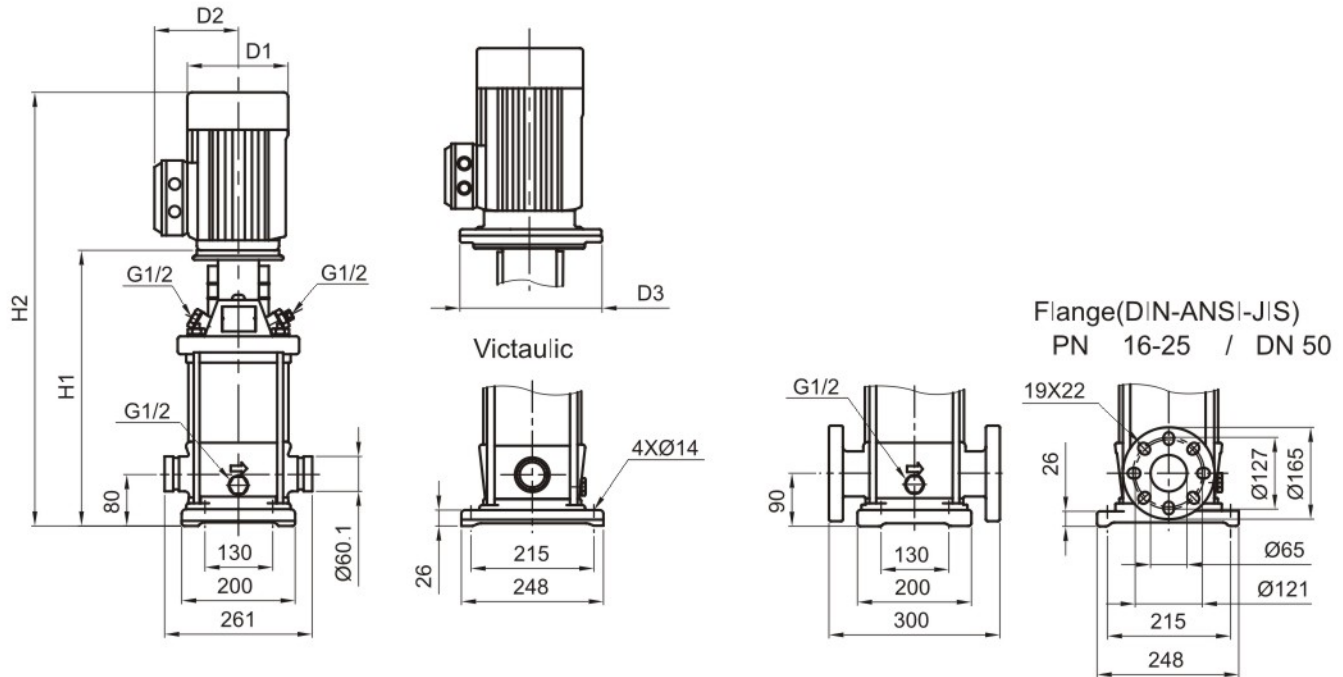

泵浦型號	電機 P ₂ [kW]	SBI, SBN								
		尺寸[mm]						淨重[kg]		
		Victaulic		DIN flange		D1	D2	D3	Victaulic	DIN flange
H1	H2	H1	H2							
SBI,SBN20-1	1.1	387	623	397	632	141	115	—	36.0	36.6
SBI,SBN20-2	2.2	403	696	413	704	177	141	—	47.7	48.3
SBI,SBN20-3	4	453	783	463	789	220	161	—	59.5	60.2
SBI,SBN20-4	5.5	530	898	540	902	235	197	300	91.7	92.3
SBI,SBN20-5	5.5	575	943	585	947	235	197	300	93.2	93.8
SBI,SBN20-6	7.5	620	1026	630	1028	235	197	300	100.9	101.6
SBI,SBN20-7	7.5	665	1071	675	1073	235	197	300	102.4	103.0
SBI,SBN20-8	11	787	1303	797	1302	318	245	350	139.7	140.3
SBI,SBN20-10	11	877	1393	887	1392	318	245	350	142.7	143.3
SBI,SBN20-12	15	967	1492	977	1487	318	245	350	155.7	156.3
SBI,SBN20-14	15	1057	1582	1067	1577	318	245	350	158.6	159.2
SBI,SBN20-17	18.5	1192	1761	1202	1752	318	245	350	187.8	188.5

性能曲綫

Vertical Multistage Centrifugal In-line Pumps



STAIRS PUMPS

SB, SBI, SBN 32

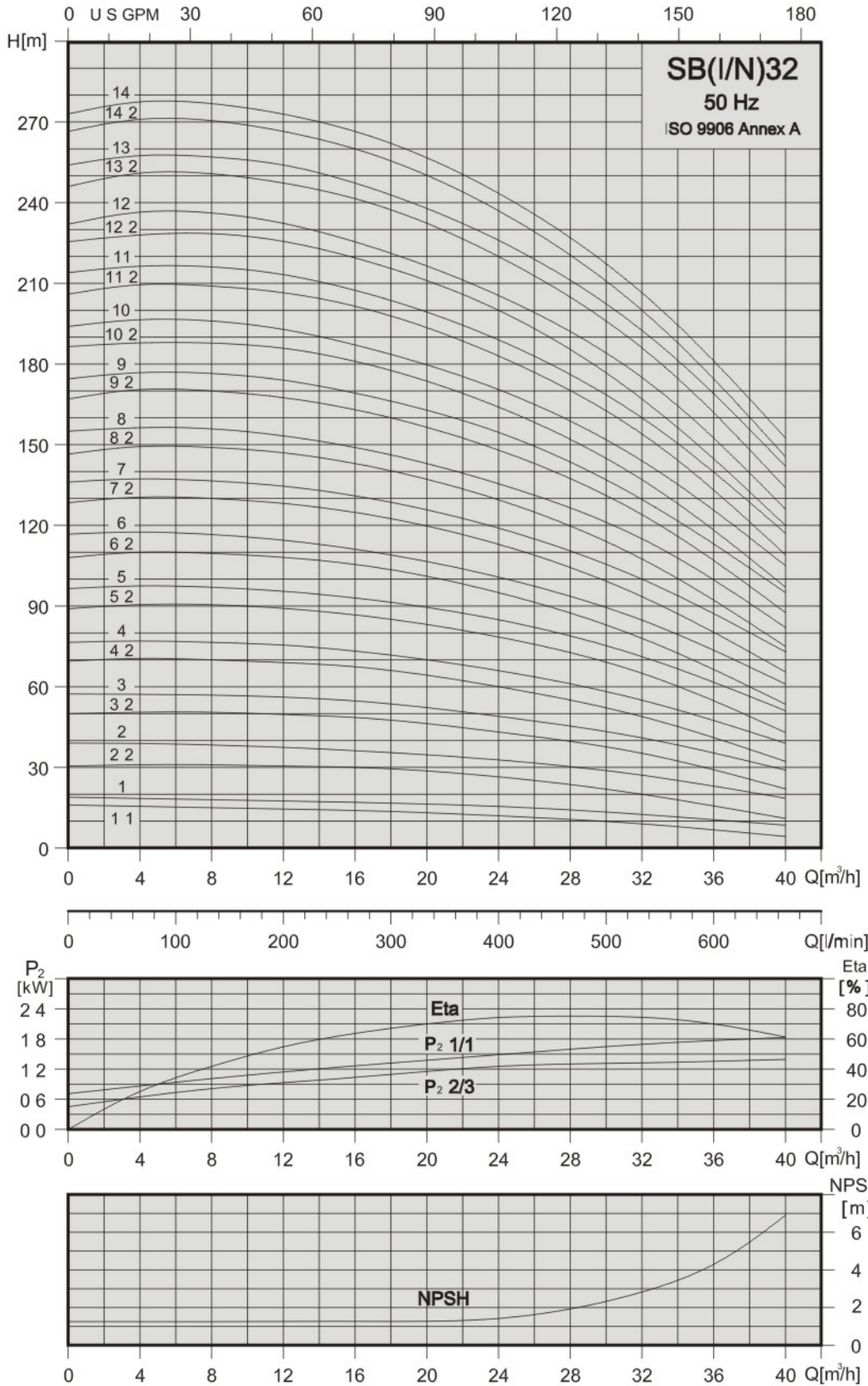

技術數據

Vertical Multistage Centrifugal In-line Pumps



STAIRS PUMPS

尺寸和重量-SB32

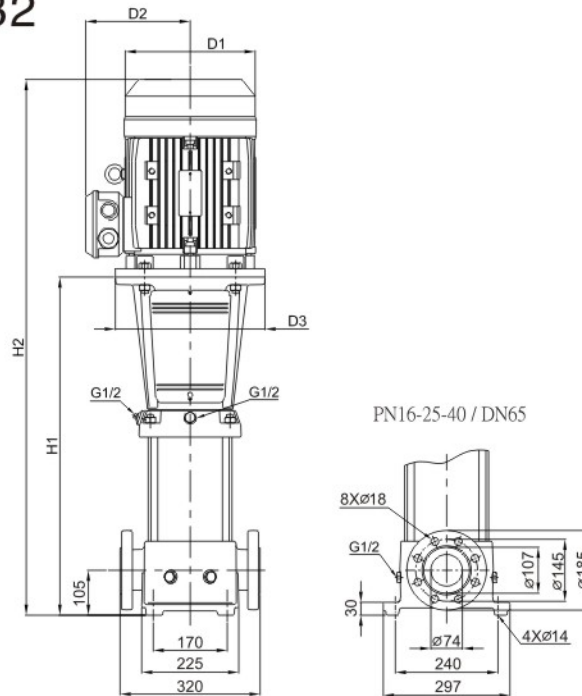

泵浦型號	電機 P ₂ [kW]	SB 尺寸[mm]					淨重 [kg] DIN flange
		DIN flange		D1	D2	D3	
		H1	H2				
SB 32-1-1	1.5	504	795	177	141	280	71.5
SB 32-1	2.2	504	795	177	141	280	74.3
SB 32-2-2	3	574	935	197	147	280	84.2
SB 32-2	4	574	900	220	161	280	87.6
SB 32-3-2	5.5	644	1006	235	197	300	110.2
SB 32-3	5.5	644	1006	235	197	300	110.2
SB 32-4-2	7.5	714	1112	235	197	300	119.5
SB 32-4	7.5	714	1112	235	197	300	119.5
SB 32-5-2	11	894	1399	318	245	350	163.3
SB 32-5	11	894	1399	318	245	350	163.3
SB 32-6-2	11	964	1469	318	245	350	166.3
SB 32-6	11	964	1469	318	245	350	166.3
SB 32-7-2	15	1034	1544	318	245	350	179.5
SB 32-7	15	1034	1544	318	245	350	179.5
SB 32-8-2	15	1104	1614	318	245	350	182.6
SB 32-8	15	1104	1614	318	245	350	182.6
SB 32-9-2	18.5	1174	1724	318	245	350	210.6
SB 32-9	18.5	1174	1724	318	245	350	210.6
SB 32-10-2	18.5	1244	1794	318	245	350	212.7
SB 32-10	18.5	1244	1794	318	245	350	213.7
SB 32-11-2	22	1314	1894	358	265	350	258.8
SB 32-11	22	1314	1894	358	265	350	258.8
SB 32-12-2	22	1384	1964	358	265	350	260.8
SB 32-12	22	1384	1964	358	265	350	260.8
SB 32-13-2	30	1454	2114	420	295	400	328.2
SB 32-13	30	1454	2114	420	295	400	328.2
SB 32-14-2	30	1524	2184	420	295	400	331.3
SB 32-14	30	1524	2184	420	295	400	331.3

技術數據

Vertical Multistage Centrifugal In-line Pumps



STAIRS PUMPS

尺寸和重量-SBI,SBN32

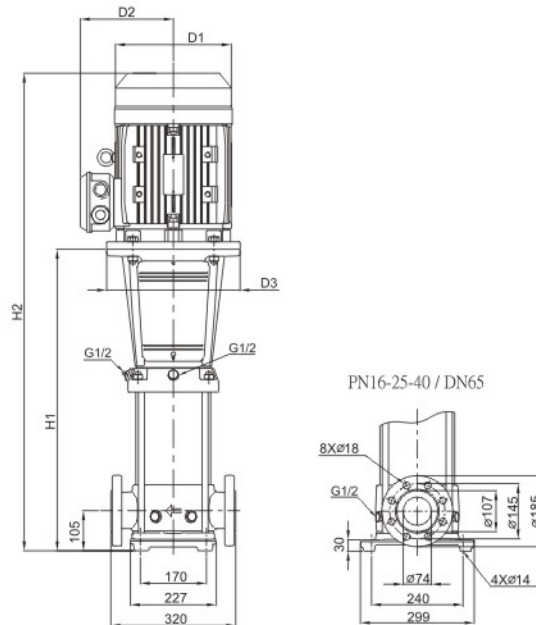

泵浦型號	電機 P ₂ [kW]	SBI,SBN 尺寸[mm]					淨重 [kg]
		DIN flange		D1	D2	D3	
		H1	H2				DIN flange
SBI,SBN 32-1-1	1.5	504	795	177	141	280	66.5
SBI,SBN 32-1	2.2	504	795	177	141	280	69.3
SBI,SBN 32-2-2	3	574	935	197	147	280	79.1
SBI,SBN 32-2	4	574	900	220	161	280	82.5
SBI,SBN 32-3-2	5.5	644	1006	235	197	300	105.1
SBI,SBN 32-3	5.5	644	1006	235	197	300	105.1
SBI,SBN 32-4-2	7.5	714	1112	235	197	300	114.5
SBI,SBN 32-4	7.5	714	1112	235	197	300	114.6
SBI,SBN 32-5-2	11	894	1399	318	245	350	158.2
SBI,SBN 32-5	11	894	1399	318	245	350	158.3
SBI,SBN 32-6-2	11	964	1469	318	245	350	161.3
SBI,SBN 32-6	11	964	1469	318	245	350	161.4
SBI,SBN 32-7-2	15	1034	1544	318	245	350	174.6
SBI,SBN 32-7	15	1034	1544	318	245	350	174.6
SBI,SBN 32-8-2	15	1104	1614	318	245	350	177.9
SBI,SBN 32-8	15	1104	1614	318	245	350	177.9
SBI,SBN 32-9-2	18.5	1174	1724	318	245	350	205.5
SBI,SBN 32-9	18.5	1174	1724	318	245	350	205.6
SBI,SBN 32-10-2	18.5	1244	1794	318	245	350	208.1
SBI,SBN 32-10	18.5	1244	1794	318	245	350	208.2
SBI,SBN 32-11-2	22	1314	1894	358	265	350	253.6
SBI,SBN 32-11	22	1314	1894	358	265	350	253.6
SBI,SBN 32-12-2	22	1384	1964	358	265	350	256.3
SBI,SBN 32-12	22	1384	1964	358	265	350	256.3
SBI,SBN 32-13-2	30	1454	2114	420	295	400	323.6
SBI,SBN 32-13	30	1454	2114	420	295	400	323.6
SBI,SBN 32-14-2	30	1524	2184	420	295	400	326.3
SBI,SBN 32-14	30	1524	2184	420	295	400	326.3

性能曲綫

Vertical Multistage Centrifugal In-line Pumps



STAIRS PUMPS

SB, SBI, SBN 45

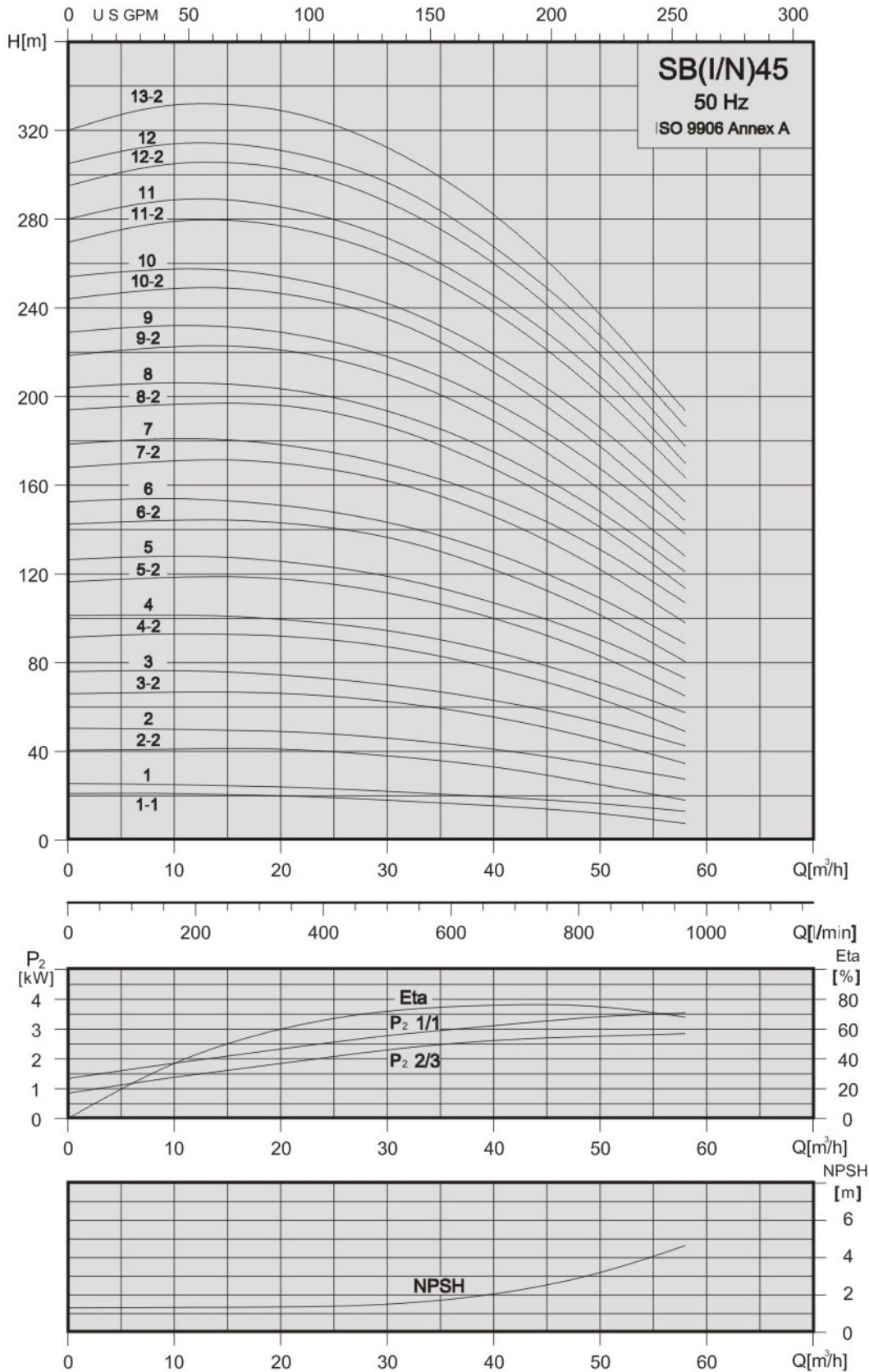

技術數據

Vertical Multistage Centrifugal In-line Pumps



STAIRS PUMPS

尺寸和重量-SB45

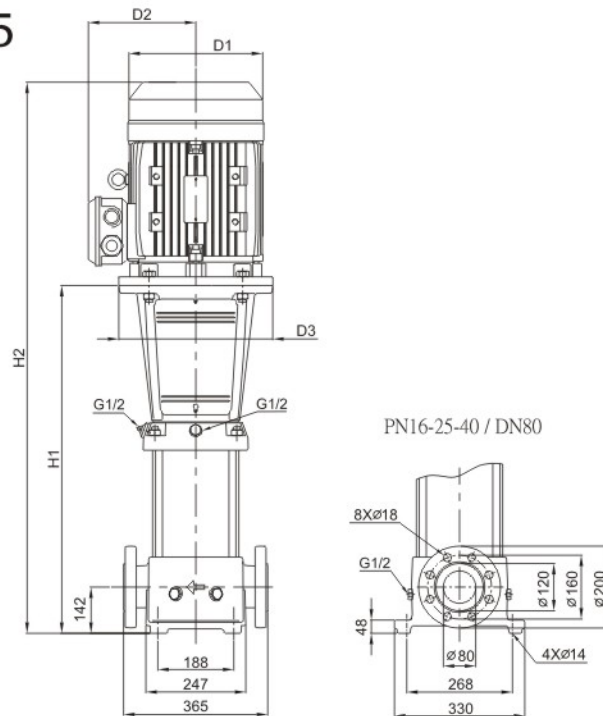

泵浦型號	電機 P ₂ [kW]	SB 尺寸[mm]					淨重 [kg]
		DIN flange		D1	D2	D3	
		H1	H2				DIN flange
SB 45-1-1	3	561	877	197	147	280	91.7
SB 45-1	4	561	887	220	161	280	95.1
SB 45-2-2	5.5	641	1003	235	197	300	118.3
SB 45-2	7.5	641	1039	235	197	300	124.6
SB 45-3-2	11	831	1336	318	245	350	169.0
SB 45-3	11	831	1336	318	245	350	169.0
SB 45-4-2	15	911	1421	318	245	350	182.9
SB 45-4	15	911	1421	318	245	350	182.9
SB 45-5-2	18.5	991	1541	318	245	350	211.6
SB 45-5	18.5	991	1541	318	245	350	211.6
SB 45-6-2	22	1071	1651	358	265	350	258.1
SB 45-6	22	1071	1651	358	265	350	258.1
SB 45-7-2	30	1151	1811	420	295	400	326.4
SB 45-7	30	1151	1811	420	295	400	326.5
SB 45-8-2	30	1231	1891	420	295	400	330.2
SB 45-8	30	1231	1891	420	295	400	331.3
SB 45-9-2	30	1311	1971	420	295	400	334.0
SB 45-9	37	1311	1971	420	295	400	347.0
SB 45-10-2	37	1391	2051	420	295	400	350.7
SB 45-10	37	1391	2051	420	295	400	350.7
SB 45-11-2	45	1471	2161	470	325	450	412.5
SB 45-11	45	1471	2161	470	325	450	412.5
SB 45-12-2	45	1551	2241	470	325	450	416.2
SB 45-12	45	1551	2241	470	325	450	416.2
SB 45-13-2	45	1631	2321	470	325	450	419.9

技術數據

Vertical Multistage Centrifugal In-line Pumps



STAIRS PUMPS

尺寸和重量-SBI,SBN45

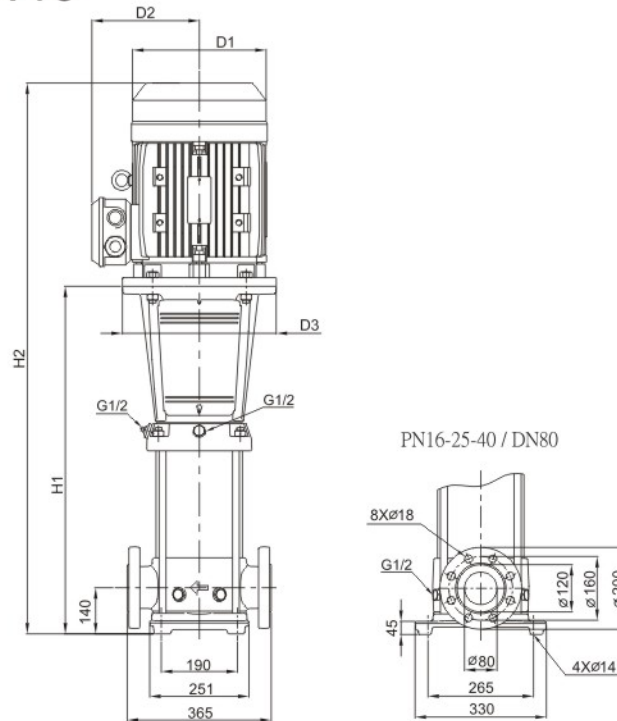

泵浦型號	電機 P ₂ [kW]	SBI,SBN 尺寸[mm]					淨重 [kg] DIN flange
		DIN flange		D1	D2	D3	
		H1	H2				
SBI,SBN45-1-1	3	559	875	197	147	280	82.9
SBI,SBN 45-1	4	559	885	220	161	280	86.3
SBI,SBN 45-2-2	5.5	639	1001	235	197	300	109.5
SBI,SBN 45-2	7.5	639	1037	235	197	300	115.8
SBI,SBN 45-3-2	11	829	1334	318	245	350	160.2
SBI,SBN 45-3	11	829	1334	318	245	350	160.2
SBI,SBN 45-4-2	15	909	1419	318	245	350	174.1
SBI,SBN 45-4	15	909	1419	318	245	350	174.1
SBI,SBN 45-5-2	18.5	989	1539	318	245	350	202.8
SBI,SBN 45-5	18.5	989	1539	318	245	350	202.8
SBI,SBN 45-6-2	22	1069	1649	358	265	350	249.3
SBI,SBN 45-6	22	1069	1649	358	265	350	249.3
SBI,SBN 45-7-2	30	1149	1809	420	295	400	317.7
SBI,SBN 45-7	30	1149	1809	420	295	400	317.7
SBI,SBN 45-8-2	30	1229	1889	420	295	400	321.4
SBI,SBN 45-8	30	1229	1889	420	295	400	321.5
SBI,SBN 45-9-2	30	1309	1969	420	295	400	325.2
SBI,SBN 45-9	37	1309	1969	420	295	400	338.2
SBI,SBN 45-10-2	37	1389	2049	420	295	400	341.9
SBI,SBN 45-10	37	1389	2049	420	295	400	341.9
SBI,SBN 45-11-2	45	1469	2159	470	325	450	403.7
SBI,SBN 45-11	45	1469	2159	470	325	450	403.7
SBI,SBN 45-12-2	45	1549	2239	470	325	450	407.4
SBI,SBN 45-12	45	1549	2239	470	325	450	407.4
SBI,SBN 45-13-2	45	1629	2319	470	325	450	411.1

性能曲綫

Vertical Multistage Centrifugal In-line Pumps



STAIRS PUMPS

SB, SBI, SBN 64

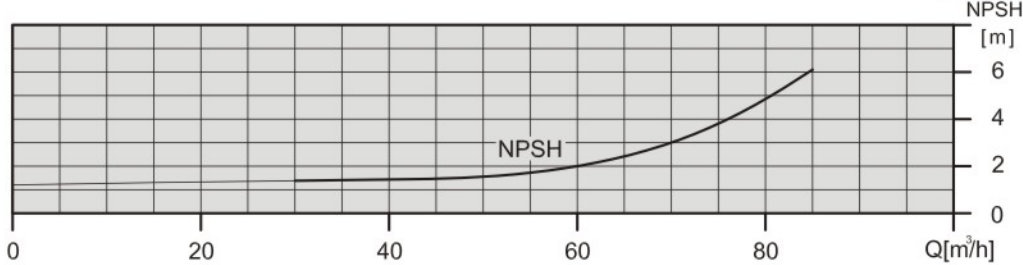
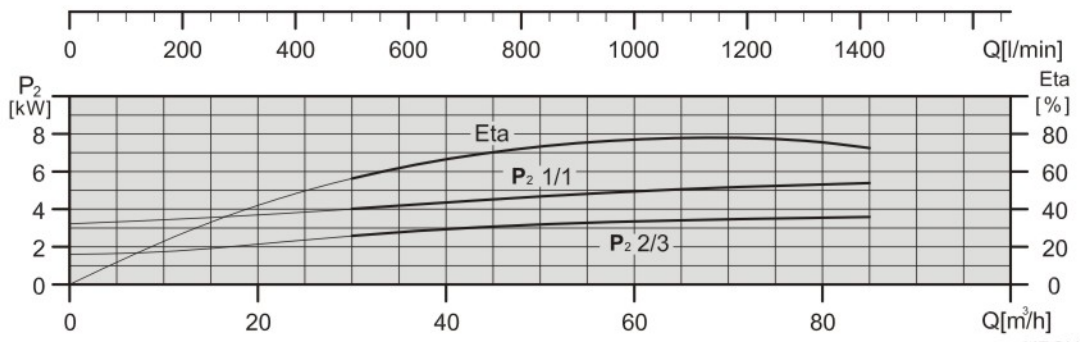
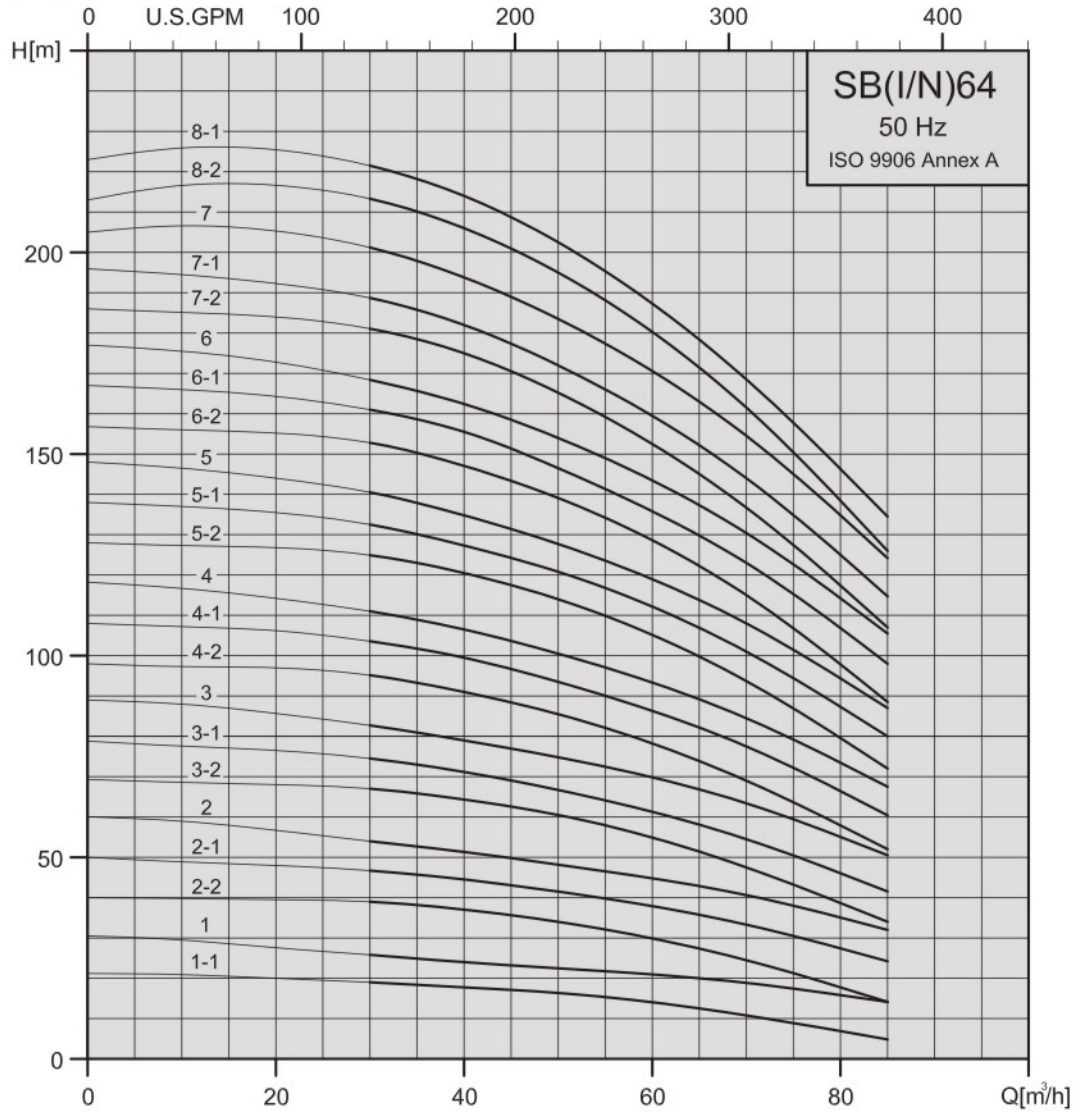

技術數據

Vertical Multistage Centrifugal In-line Pumps



STAIRS PUMPS

尺寸和重量-SB64

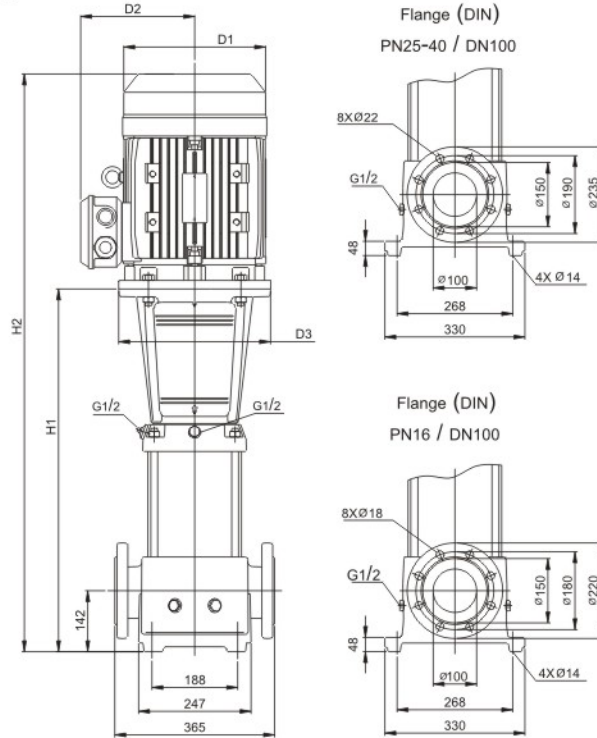

泵浦型號	電機 P ₂ [kW]	SB 尺寸[mm]					淨重 [kg]
		DIN flange		D1	D2	D3	
		H1	H2				DIN flange
SB 64-1-1	4	563	889	220	161	280	88.9
SB 64-1	5.5	563	613	235	197	300	108.3
SB 64-2-2	7.5	646	702	235	197	300	118.7
SB 64-2-1	11	756	1261	318	245	350	159.3
SB 64-2	11	756	1261	318	245	350	159.3
SB 64-3-2	15	838	1348	318	245	350	174.0
SB 64-3-1	15	838	1348	318	245	350	174.0
SB 64-3	18.5	838	1388	318	245	350	198.9
SB 64-4-2	18.5	921	1471	318	245	350	202.9
SB 64-4-1	22	921	1501	358	265	350	245.7
SB 64-4	22	921	1501	358	265	350	245.7
SB 64-5-2	30	1003	1663	420	295	400	314.3
SB 64-5-1	30	1003	1663	420	295	400	314.3
SB 64-5	30	1003	1663	420	295	400	314.3
SB 64-6-2	30	1086	1746	420	295	400	318.2
SB 64-6-1	37	1086	1746	420	295	400	331.2
SB 64-6	37	1086	1746	420	295	400	331.2
SB 64-7-2	37	1168	1828	420	295	400	335.3
SB 64-7-1	37	1168	1828	420	295	400	335.3
SB 64-7	45	1172	1862	470	325	450	393.4
SB 64-8-2	45	1255	1945	470	325	450	397.5
SB 64-8-1	45	1255	1945	470	325	450	397.5

技術數據

Vertical Multistage Centrifugal In-line Pumps



STAIRS PUMPS

尺寸和重量-SBI,SBN 64

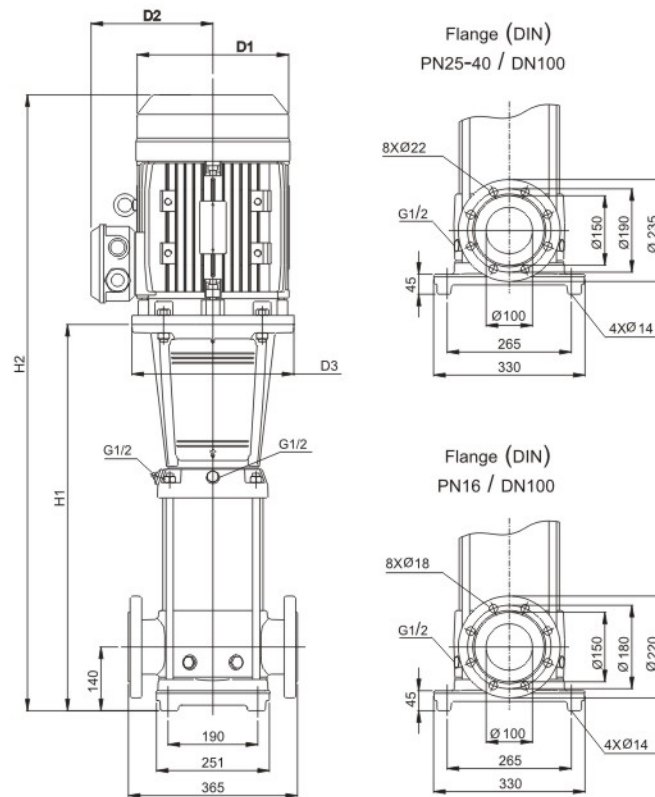

泵浦型號	電機 P ₂ [kW]	SBI,SBN					淨重 [kg] DIN flange
		DIN flange		尺寸[mm]			
		H1	H2	D1	D2	D3	
SBI,SBN 64-1-1	4	563	889	220	161	280	81.8
SBI,SBN 64-1	5.5	563	613	235	197	300	101.3
SBI,SBN 64-2-2	7.5	646	702	235	197	300	111.7
SBI,SBN 64-2-1	11	756	1261	318	245	350	152.3
SBI,SBN 64-2	11	756	1261	318	245	350	152.3
SBI,SBN 64-3-2	15	838	1348	318	245	350	166.5
SBI,SBN 64-3-1	15	838	1348	318	245	350	166.5
SBI,SBN 64-3	18.5	838	1388	318	245	350	191.4
SBI,SBN 64-4-2	18.5	921	1471	318	245	350	195.4
SBI,SBN 64-4-1	22	921	1501	358	265	350	238.1
SBI,SBN 64-4	22	921	1501	358	265	350	238.1
SBI,SBN 64-5-2	30	1003	1663	420	295	400	306.7
SBI,SBN 64-5-1	30	1003	1663	420	295	400	306.7
SBI,SBN 64-5	30	1003	1663	420	295	400	306.7
SBI,SBN 64-6-2	30	1086	1746	420	295	400	310.7
SBI,SBN 64-6-1	37	1086	1746	420	295	400	323.7
SBI,SBN 64-6	37	1086	1746	420	295	400	323.7
SBI,SBN 64-7-2	37	1168	1828	420	295	400	327.7
SBI,SBN 64-7-1	37	1168	1828	420	295	400	327.7
SBI,SBN 64-7	45	1172	1862	470	325	450	385.8
SBI,SBN 64-8-2	45	1255	1945	470	325	450	390.0
SBI,SBN 64-8-1	45	1255	1945	470	325	450	390.0

性能曲綫

Vertical Multistage Centrifugal In-line Pumps



STAIRS PUMPS

SB, SBI, SBN 90

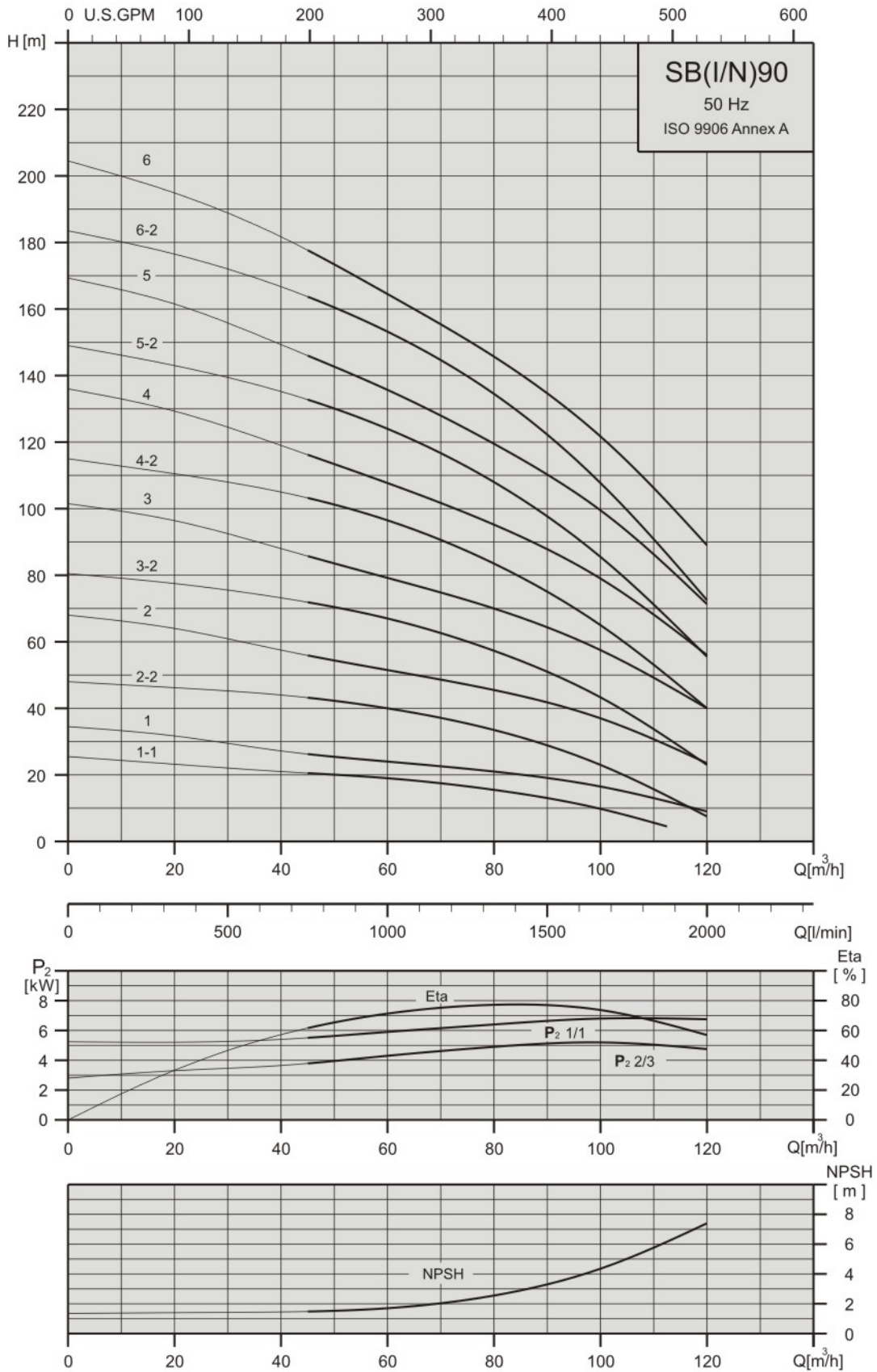

技術數據

Vertical Multistage Centrifugal In-line Pumps



STAIRS PUMPS

尺寸和重量-SB90

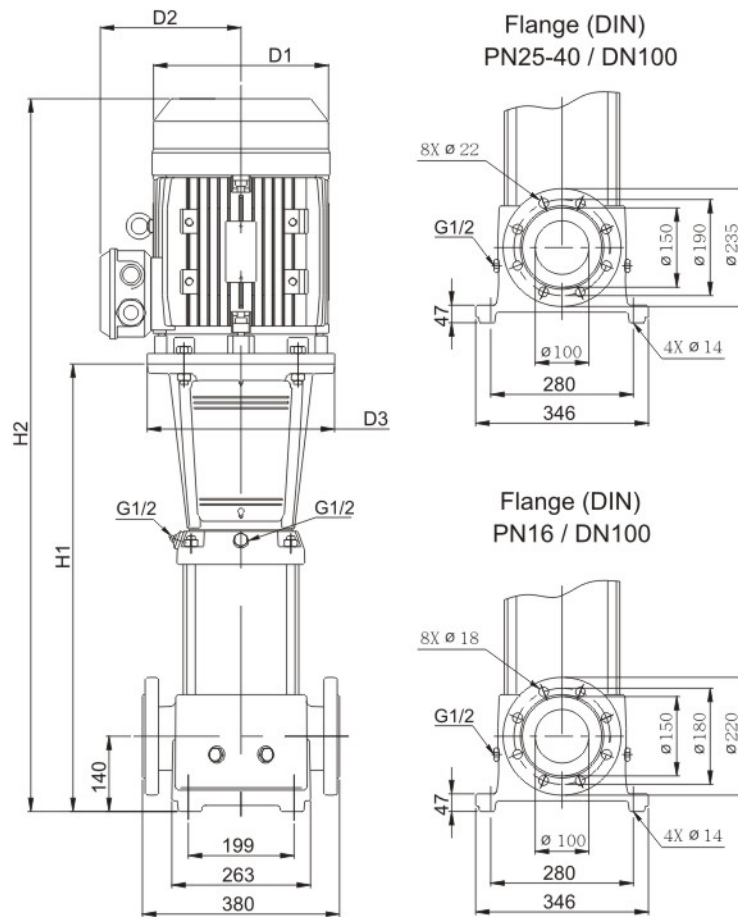

泵浦型號	電機	SB					淨重 [kg]
		尺寸[mm]			D1	D2	
	P ₂ [kW]	DIN flange		DIN flange			
SB 90-1-1	5.5	H1	H2	D1	D2	D3	122.2
SB 90-1	7.5	572	934	235	197	300	128.5
SB 90-2-2	11	774	1279	318	245	350	174.4
SB 90-2	15	774	1284	318	245	350	184.5
SB 90-3-2	18.5	866	1416	318	245	350	214.7
SB 90-3	22	866	1446	358	265	350	257.5
SB 90-4-2	30	958	1618	420	295	400	327.3
SB 90-4	30	958	1618	420	295	400	327.3
SB 90-5-2	37	1050	1710	420	295	400	346.9
SB 90-5	37	1050	1710	420	295	400	346.9
SB 90-6-2	45	1142	1832	470	325	450	410.2
SB 90-6	45	1142	1832	470	325	450	410.3



尺寸和重量-SBI,SBN 90

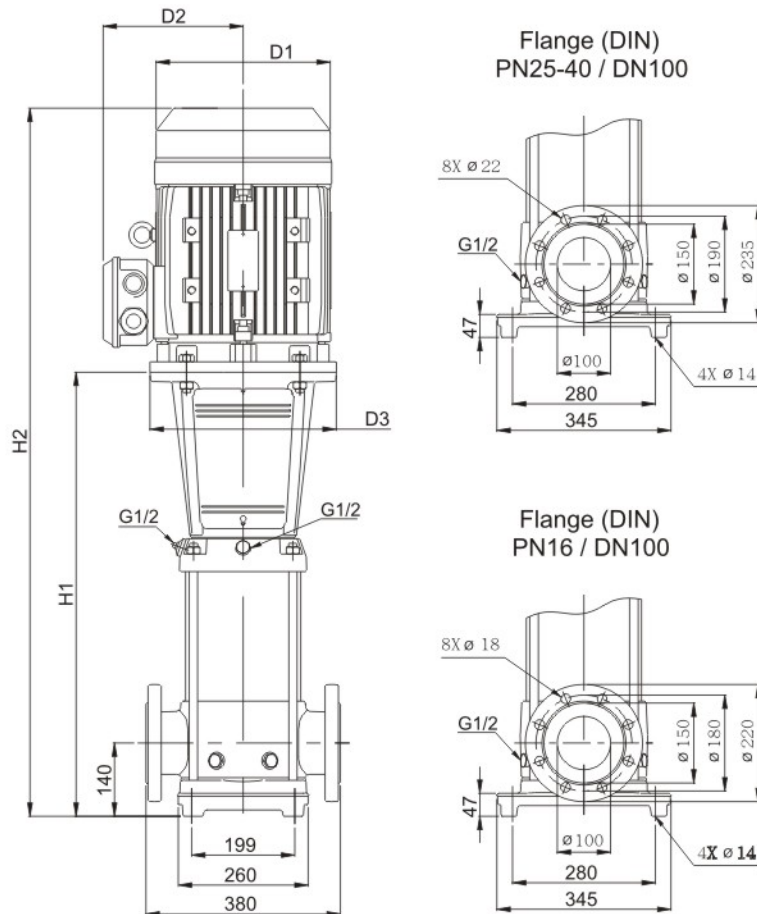

泵浦型號	電機 P ₂ [kW]	SBI,SBN					淨重 [kg]
		尺寸[mm]		D1	D2	D3	
		DIN flange					DIN flange
SBI,SBN 90-1-1	5.5	H1	H2	D1	D2	D3	112.1
SBI,SBN 90-1	7.5	576	938	235	197	300	118.4
SBI,SBN 90-2-2	11	778	1283	318	245	350	164.2
SBI,SBN 90-2	15	778	1288	318	245	350	174.3
SBI,SBN 90-3-2	18.5	870	1420	318	245	350	204.4
SBI,SBN 90-3	22	870	1450	358	265	350	247.2
SBI,SBN 90-4-2	30	962	1622	420	295	400	316.9
SBI,SBN 90-4	30	962	1622	420	295	400	316.9
SBI,SBN 90-5-2	37	1054	1714	420	295	400	336.9
SBI,SBN 90-5	37	1054	1714	420	295	400	337.0
SBI,SBN 90-6-2	45	1146	1836	470	325	450	400.0
SBI,SBN 90-6	45	1146	1836	470	325	450	400.1

性能曲綫

Vertical Multistage Centrifugal In-line Pumps



STAIRS PUMPS

SB, SBI, SBN 120

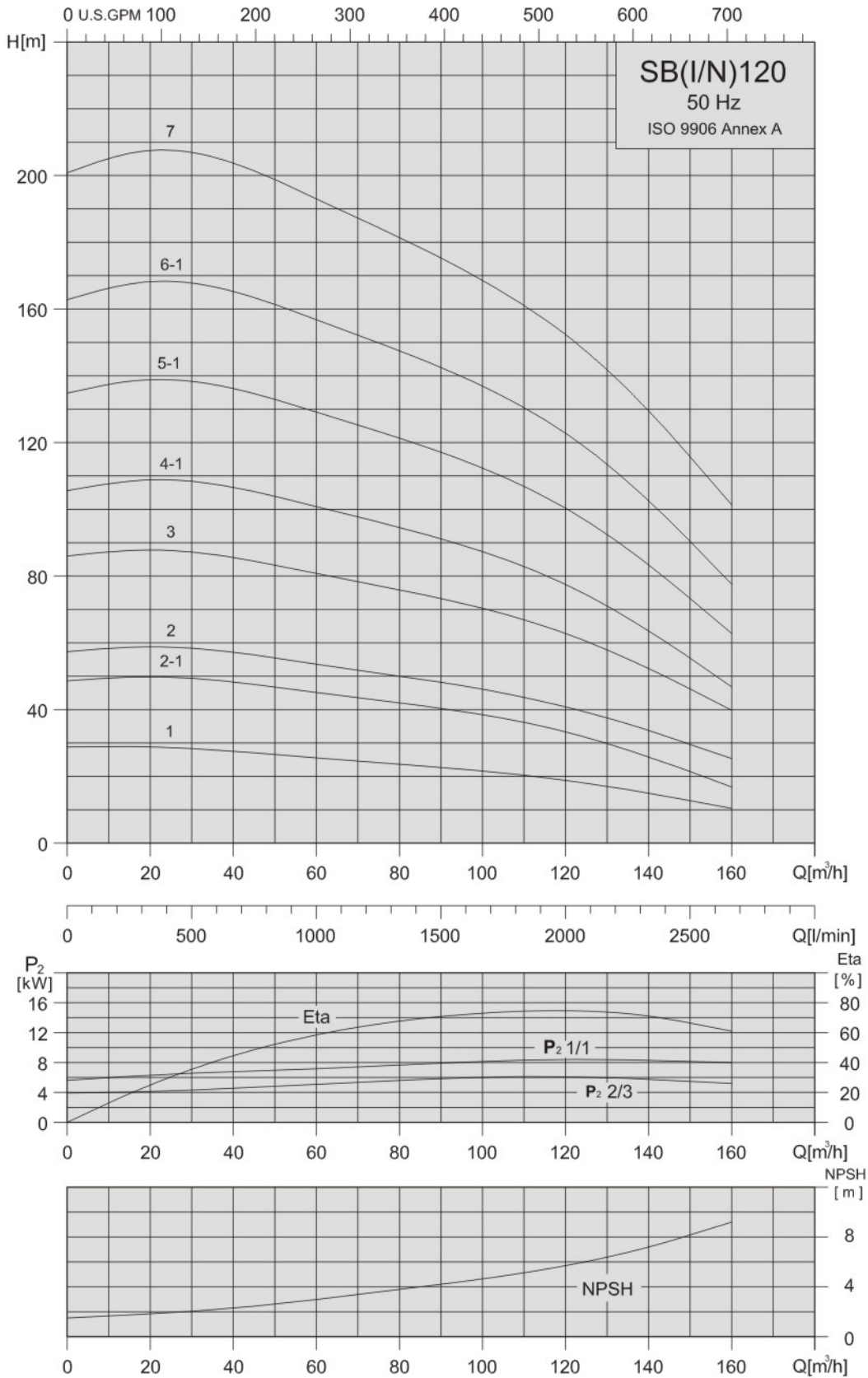

技術數據

Vertical Multistage Centrifugal In-line Pumps



STAIRS PUMPS

尺寸和重量-SB120

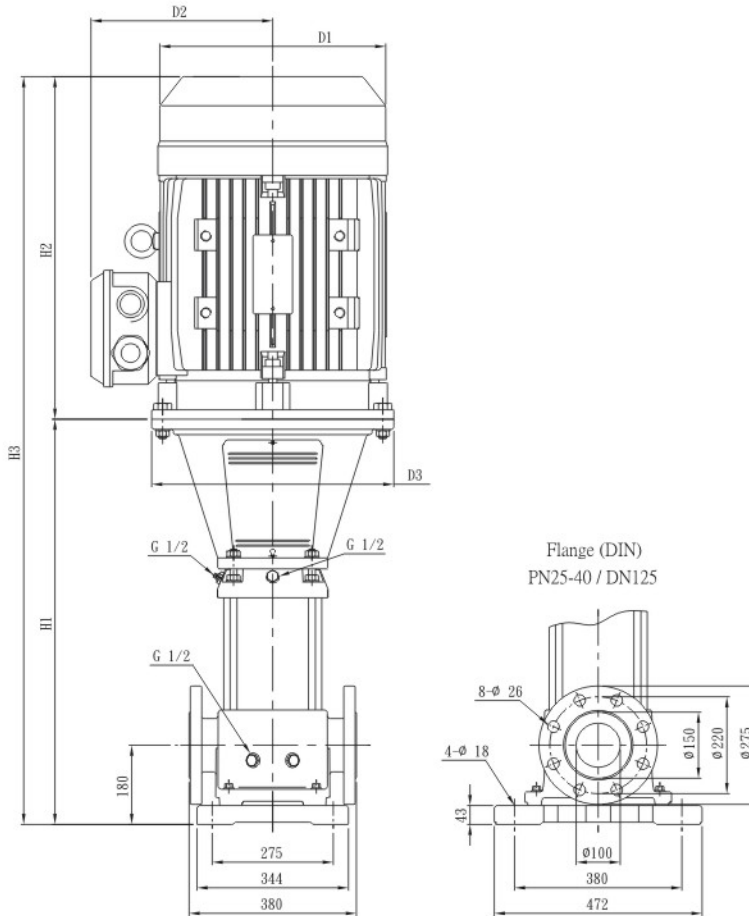

泵浦型號	電機 P ₂ [kW]	SB						淨重 [kg] DIN flange
		尺寸[mm]						
		DIN flange			D1	D2	D3	
H1	H2	H3						
SB 120-1-1	11	834	505	1339	318	245	350	200.1
SB 120-2-1	18.5	990	550	1540	318	245	350	245.1
SB 120-2	22	990	580	1570	358	265	350	291.8
SB 120-3	30	1145	660	1805	420	295	400	362.5
SB 120-4-1	37	1301	660	1961	420	295	400	385.5
SB 120-5-1	45	1460	690	2150	470	325	450	453.6
SB 120-6-1	55	1642	770	2412	510	355	550	578.8
SB 120-7	75	1797	845	2642	580	410	550	751.4



尺寸和重量-SBI,SBN120

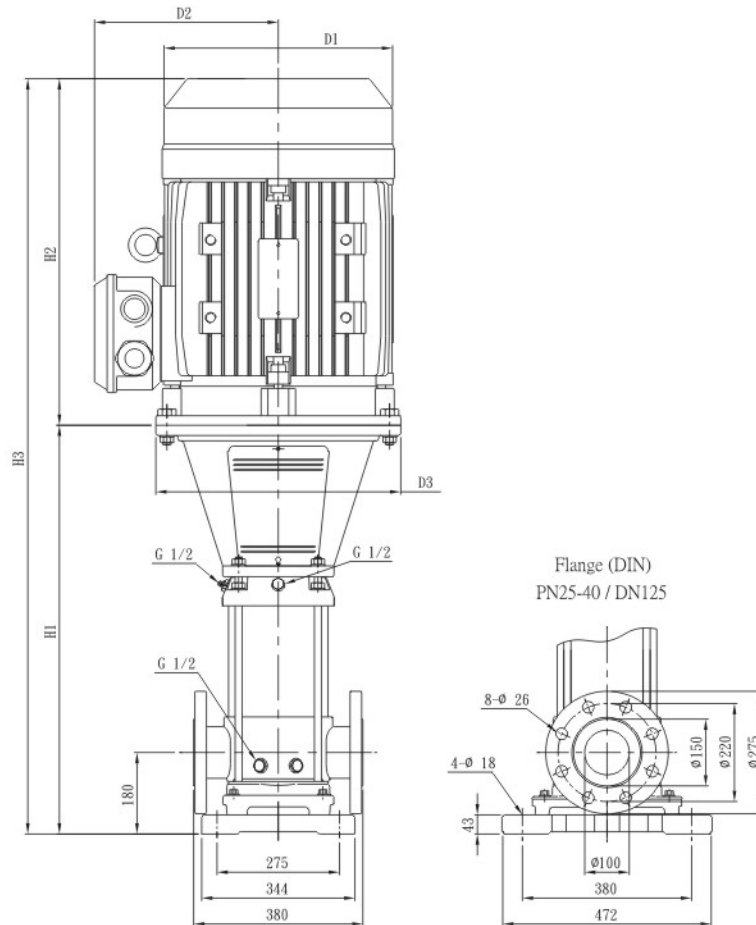

泵浦型號	電機	SBI,SBN						淨重 [kg]
		尺寸[mm]						
	P ₂ [kW]	DIN flange			D1	D2	D3	DIN flange
		H1	H2	H3				
SBI,SBN 120-1-1	11	837	505	1342	318	245	350	184.3
SBI,SBN 120-2-1	18.5	993	550	1543	318	245	350	229.5
SBI,SBN 120-2	22	993	580	1573	358	265	350	276.1
SBI,SBN 120-3	30	1149	660	1809	420	295	400	346.9
SBI,SBN 120-4-1	37	1304	660	1964	420	295	400	370.1
SBI,SBN 120-5-1	45	1463	690	2153	470	325	450	438.3
SBI,SBN 120-6-1	55	1645	770	2415	510	355	550	563.8
SBI,SBN 120-7	75	1800	845	2645	580	410	550	736.5

性能曲綫

Vertical Multistage Centrifugal In-line Pumps



STAIRS PUMPS

SB, SBI, SBN 150

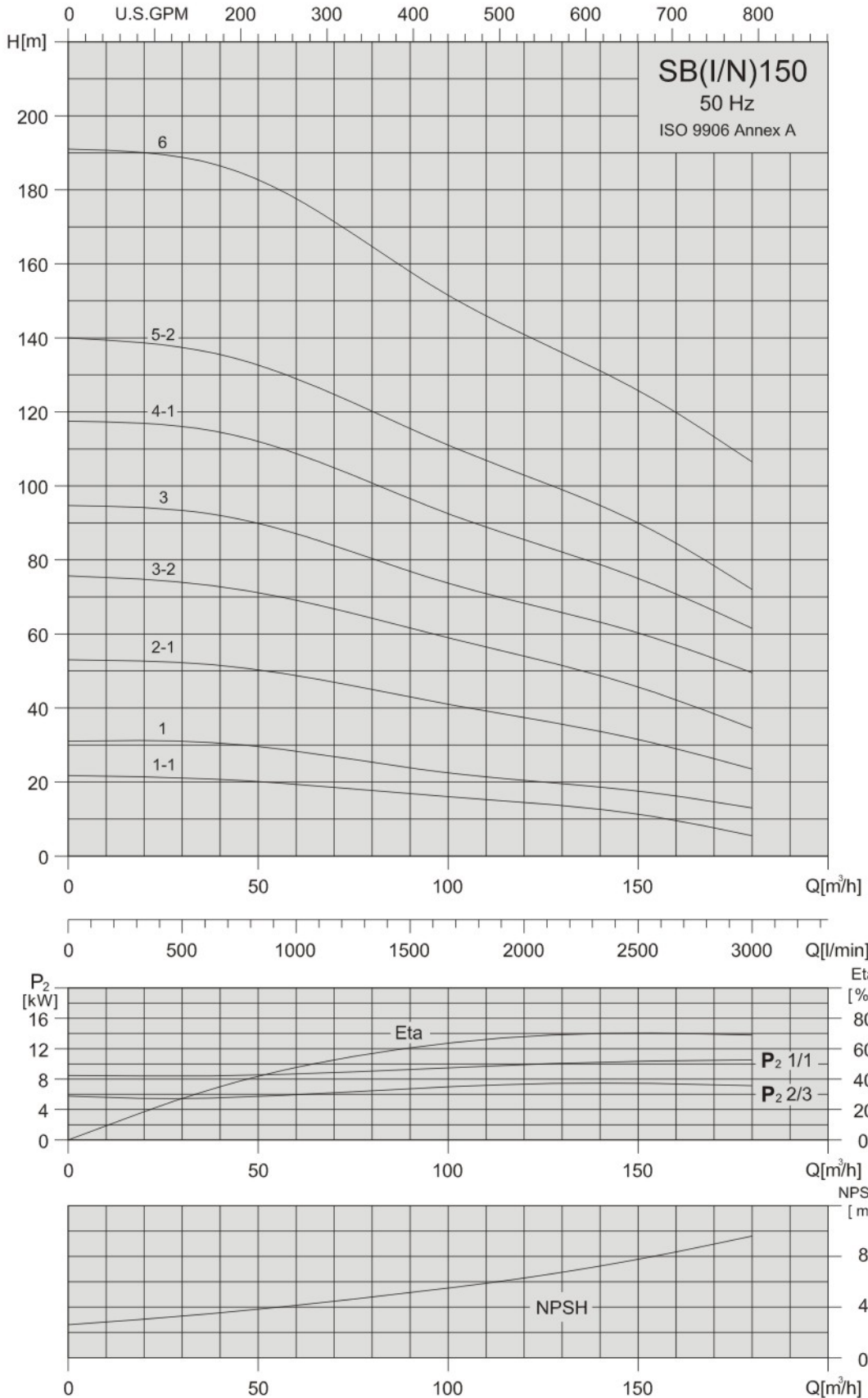



尺寸和重量-SB 150

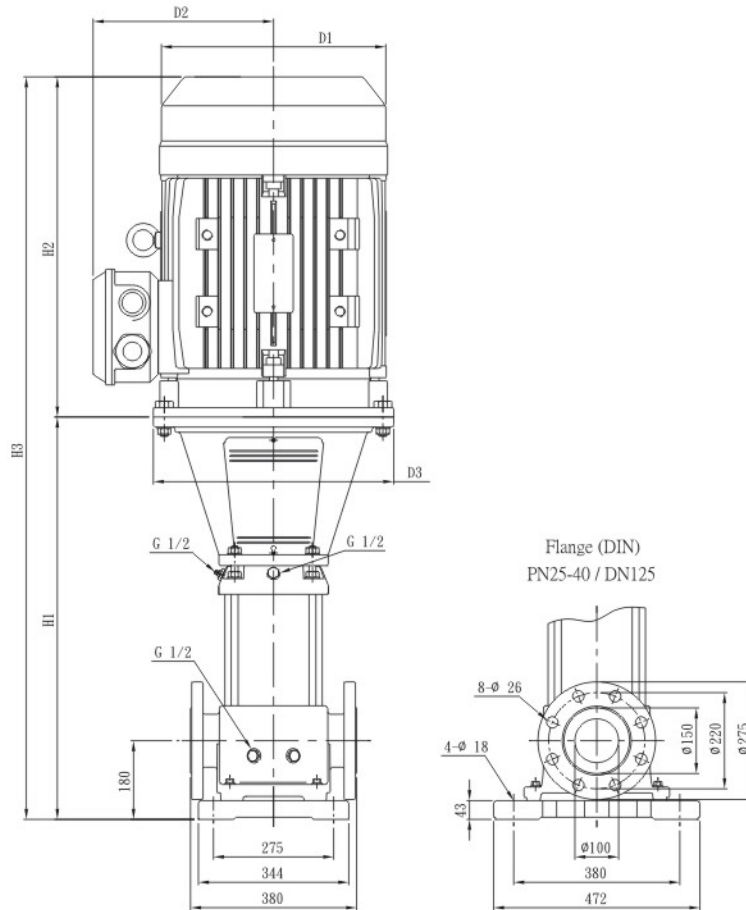

泵浦型號	電機 P ₂ [kW]	SB						淨重 [kg] DIN flange
		DIN flange			D1	D2	D3	
		H1	H2	H3				
SB 150-1-1	11	834	505	1339	318	245	350	200.0
SB 150-1	15	834	510	1344	318	245	350	210.1
SB 150-2-1	22	990	580	1570	358	265	350	287.8
SB 150-3-2	30	1145	660	1805	420	295	400	362.3
SB 150-3	37	1145	660	1805	420	295	400	375.4
SB 150-4-1	45	1305	690	1995	470	325	450	443.4
SB 150-5-2	55	1486	770	2256	510	355	550	568.7
SB 150-6	75	1642	845	2487	580	410	550	741.0

技術數據

Vertical Multistage Centrifugal In-line Pumps



STAIRS PUMPS

尺寸和重量-SBI,SBN 150

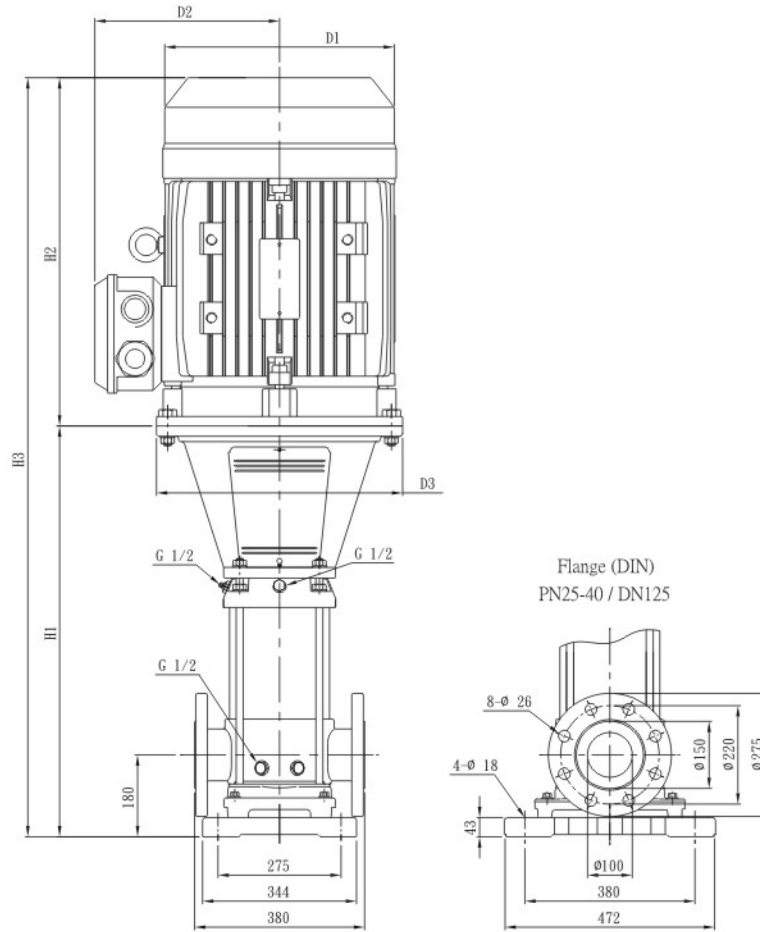

泵浦型號	電機	SBI,SBN						淨重 [kg]
		尺寸 [mm]						
	P ₂ [kW]	DIN flange			D1	D2	D3	DIN flange
		H1	H2	H3				
SBI,SBN 150-1-1	11	837	505	1342	318	245	350	173.4
SBI,SBN 150-1	15	837	510	1347	318	245	350	183.5
SBI,SBN 150-2-1	22	993	580	1573	358	265	350	271.6
SBI,SBN 150-3-2	30	1148	660	1808	420	295	400	346.2
SBI,SBN 150-3	37	1148	660	1808	420	295	400	359.2
SBI,SBN 150-4-1	45	1308	690	1998	470	325	450	427.4
SBI,SBN 150-5-2	55	1489	770	2259	510	355	550	552.8
SBI,SBN 150-6	75	1645	845	2490	580	410	550	725.5

輸送液體說明

Vertical Multistage Centrifugal In-line Pumps



STAIRS PUMPS

輸送液體

SB(I, N) 泵可以適用於多種液體，且有不同的特性。

SB(I)

非腐蝕性液體

用于液體的輸送，循環和冷/熱清潔水的增壓。

SBN

工業液體

輕度酸性液體

表中并未列出所有的液體。選擇表中所列的泵浦輸送相應的液體被認為是最適當的。表中內容供通常參考，并不能代替泵在特定工作條件下進行實際測試。當選擇泵浦時，要特別注意液體特性，例如：密度，凝固點，粘性以及防護要求。泵浦應用時，壓力和溫度也必須被考慮其中。

● 推薦

輸送液體	液體濃度，溫度	SB (I)		SBN	
		EPDM	Viton	EPDM	Viton
醋酸	25°C			●	
鹼性清洗劑		●			
硫酸鋁	10%, 25°C				●
氨水(A.氫氧化物)	20%, 40°C	●			
碳酸氫氨	10%, 40°C	●		●	
苯甲酸	10%, 90°C				●
硼酸	Unsaturated solution, 60°C				●
丁醇	60°C	●			
醋酸鈣	30%, 50°C	●			
氫氧化鈣	Saturated solution, 50°C	●			
鉻酸	1%, 20°C				●
冷凝水	90°C	●			
硫酸銅	Unsaturated solution, 60°C				●
完全除鹽水(軟化水)	50°C			●	
乙醇	100%, 20°C	●			
乙二醇/二甘醇	40%, 70°C	●	●	●	●
定影劑	25°C				●
蟻酸	5%, 20°C			●	

輸送液體說明

Vertical Multistage Centrifugal In-line Pumps



STAIRS PUMPS

輸送液體	液體濃度, 溫度	SB (I)		SBN	
		EPDM	Viton	EPDM	Viton
果汁	50°C				●
甘油	50%, 50°C	●			
輕質燃油		●			●
液壓油	100%, 100°C		●		
异丙醇		●			
乳酸	10%, 20°C				●
亞油酸	100%, 20°C	●			
亞麻油	60°C		●		
利口酒	60°C				●
玉米油	80°C		●		
馬來酸	50%, 50°C				●
甲醇	100%, 20°C	●			
機油	100%, 80°C	●			
油水混合物	100°C		●		
草酸	1%, 20°C			●	
花生油	100%, 80°C		●		
磷酸	20%, 20°C			●	
聚乙二醇	90°C		●		●
聚乙二醇	40%, 70°C	●			
碳酸鉀	10%, 60°C	●			
碳酸鉀	10%, 60°C	●			
碳酸氫鉀	5%, 20°C			●	
高錳酸鉀	Unsaturated solution, 80°C			●	
硫酸鉀	100%, 80°C		●		
菜籽油	100%		●		
硅油	10%, 60°C			●	
純碱	25%, 50°C			●	
碳酸氫鈉	Unsaturated solution, 80°C			●	
硝酸鈉	5%, 100°C			●	
磷酸鈉	10%, 60°C			●	
硫酸鈉	5%, 25°C				●
硫酸					
游泳池水	35°C	● SBI		●	
去離子	50°C			●	
蒸餾水	50°C			●	
碳酸水				●	
軟化水				●	
加熱水				●	
鍋爐水				●	
純淨水				●	
衝洗		● SBI		●	



天津斯特尔泵浦科技有限公司

地址：天津市華苑產業園區華天道8號
海泰信息廣場C座1011

電話：+86 (22) 58113062

傳真：+86 (22) 58113042

網址：WWW.STAIRS-PUMPS.COM