

# SP 4",6",8",10" 系列

不銹鋼深井泵

**50Hz**





# 公司介紹



天津鴻新益發科技有限公司是臺灣宏奇泵浦工業有限公司在中國大陸的專業行銷服務機構，總部位於北方經濟中心天津，是宏奇泵浦“STAIRS斯特尔”品牌產品在中國大陸集解決方案，銷售服務，倉儲物流為一體的全面整合型服務機構。為快速，近距離服務于全國各地顧客，我們已經在上海、廣州、南京、長沙、杭州、寧波、濟南、廈門、鄭州、西安、成都、重慶、大連等大中城市設立了銷售服務中心。

宏奇泵浦工業有限公司位于美麗的阿裏山脚下，成立於1981年，是臺灣最大的不銹鋼離心泵專業製造廠，全球第二大深井泵製造廠，長期與德國、日本、美國、意大利等國家的世界頂級泵浦品牌合作研製，在嘉義和臺南的6座工廠面積超過100000m<sup>2</sup>，設有加工/鑄造，衝壓/焊接，裝配/檢測，電機製造等完整的泵浦制程，每一臺斯特尔泵浦產品95%的零組件皆由宏奇製造和檢測。宏奇泵浦秉持：“持續為顧客提供專業的泵浦製造解決方案和優越的產品品質”的理念，產品行銷全球100多個國家和地區，臺灣宏奇“STAIRS斯特尔”已成為全球十大知名泵浦品牌之一。

“STAIRS斯特尔”泵浦產品主要包括：SBK,CBK浸入式不銹鋼離心泵；SB,SBI,SBN立式不銹鋼離心泵；CB,CBI,HBI,HBN臥式不銹鋼離心泵；SP不銹鋼深井泵；ST塑膠葉輪導輪深井泵；4,6型油式/屏蔽式潛水馬達；排污泵；熱水循環泵及Aquafos壓力桶等。廣泛的產品使我們提供服務於數控機床，各種工業製冷/清洗/過濾設備，製藥用水/RO反滲透等各種水處理設備，住宅/商業樓宇及冷暖器空調設備供水，電子產品製程以及家用供水設備等。

“提高效率、節約能源”是當代人類的主旋律，也是人類與地球和諧共容的可持續發展戰略。我們願意與有智慧、有遠見的您攜手合作，為了節能，高效的共同目標持續努力，讓人類的明天更加潔淨、美好！





# Stairs SP Series



## Index

### 產品數據

性能範圍	2
材質說明	3
4"深井泵	7
6"深井泵	8
8"深井泵	9
10"深井泵	10

### 性能曲綫/技術數據

SP05系列	11
SP10系列	13
SP18系列	15
SP25系列	17
SP40系列	19
SP70系列	21
SP90系列	23
SP150系列	25
SP230系列	27
SP300系列	29
SP400系列	31
SP500系列	33
SP650系列	37
SP800系列	40
SP1100系列	43

## 不銹鋼深井泵

SP4",6",8",10"不銹鋼深井泵采用高品質的耐腐蝕，耐磨損不銹鋼材料，通過先進的工業設計技術開發制造，優異的性能和堅固的結構可以保證SP系列深井泵產品在最嚴苛的工作條件下高效率,長壽命運行。

# 產品數據

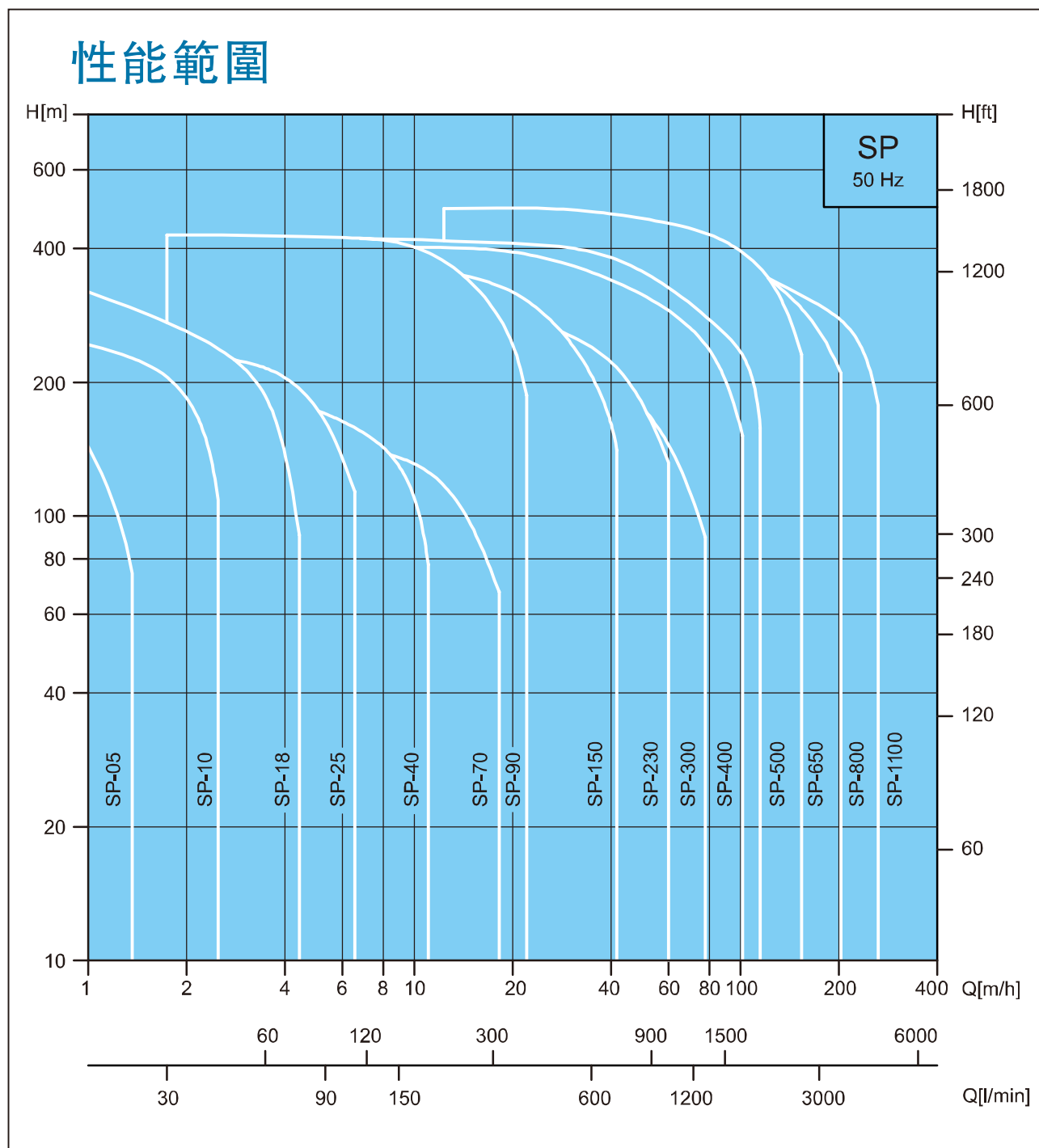





STAIRS PUMPS

# 產品數據

結構圖：SP-70

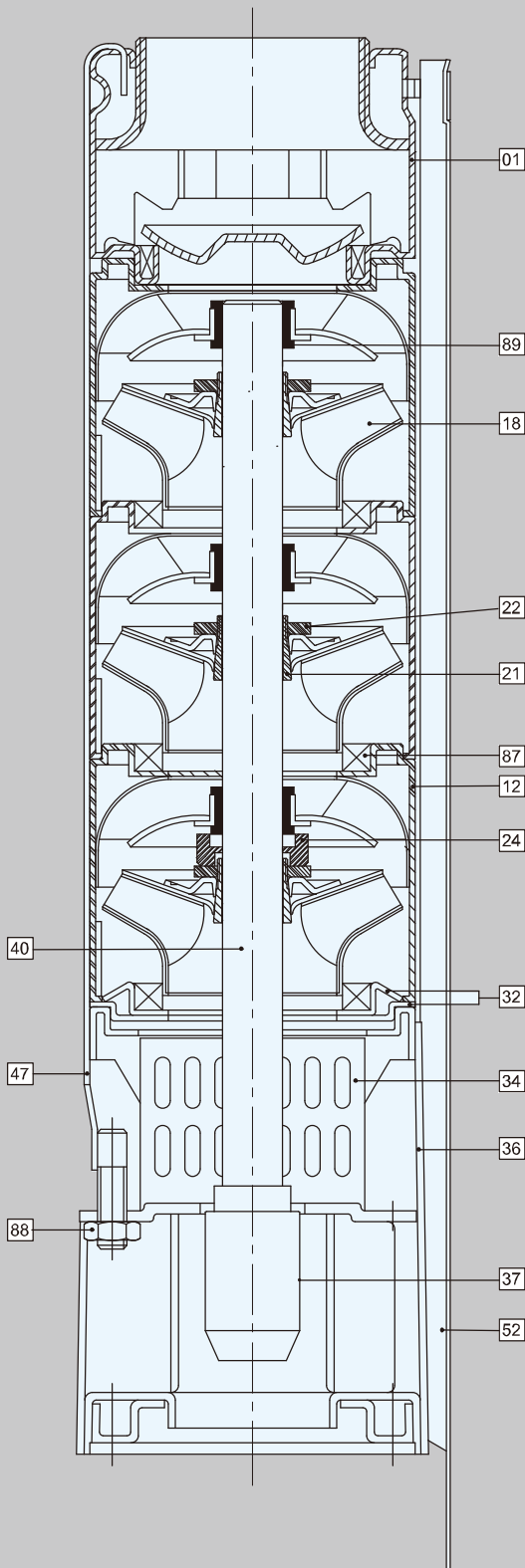

## 材質說明-4"深井泵

位置	名稱	材質	AISI
01	出水腔	不銹鋼	304
12	導輪	不銹鋼	304
18	葉輪	不銹鋼	304
21	錐套	不銹鋼	304
22	錐套螺母	不銹鋼	304
24	止水環	碳 石墨/PTFE	
32	頸環保持器	不銹鋼	304
34	過濾器	不銹鋼	304
36	支架	不銹鋼	304
40	泵軸	不銹鋼	431
37	連接器	不銹鋼	304
47	緊固帶	不銹鋼	304
52	纜纜護套	不銹鋼	304
87	頸環	SUS304+NBR	
88	螺母	不銹鋼	304
89	軸承	NBR	

\*AISI 316 不銹鋼深井泵可以按需求提供。

# 產品數據

結構圖：SP-90

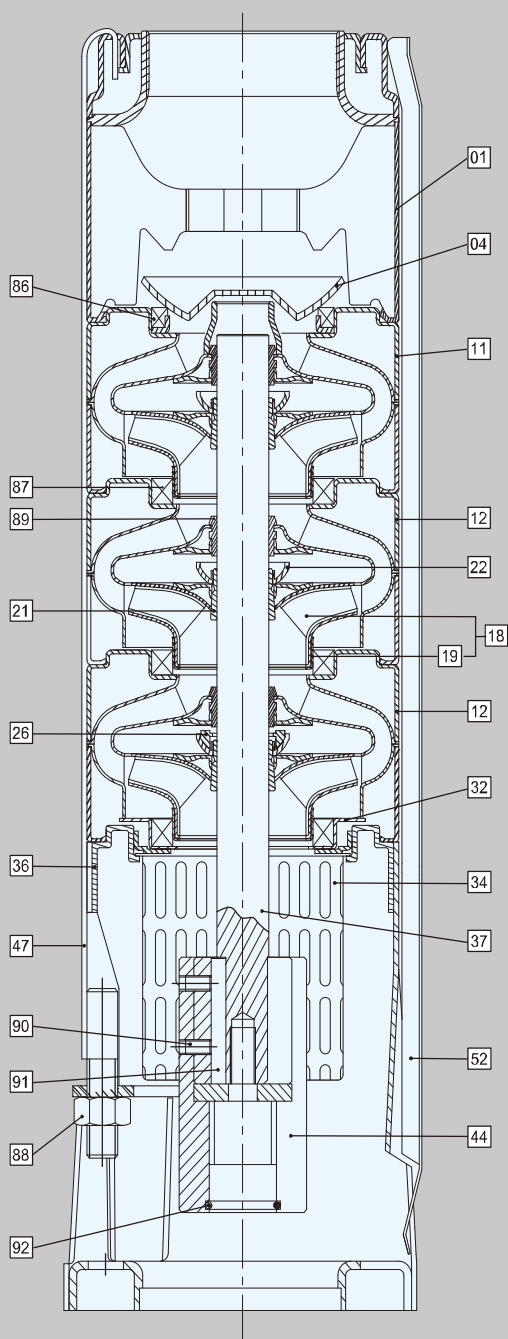

## 材質說明-6"深井泵

位置	名稱	材質	AISI
01	出水腔	不銹鋼	304
04	閘蓋	不銹鋼	304
11	頂部導輪	不銹鋼	304
12	導輪	不銹鋼	304
18	葉輪	不銹鋼	304
19	葉輪頸環	不銹鋼	304
21	錐套	不銹鋼	304
22	錐套螺母	不銹鋼	304
26	止水環	碳	
	間隔墊圈	石墨/PTFE	
32	頸環保持器	不銹鋼	304
34	過濾器	不銹鋼	304
36	支架	不銹鋼	304
37	泵軸	不銹鋼	431
44	連接器	不銹鋼	304
47	緊固帶	不銹鋼	304
52	纜纜護套	不銹鋼	304
86	閘座	SUS304+NBR	
87	頸環	SUS304+NBR	
88	螺母	不銹鋼	304
89	軸承	NBR	
90	螺栓	不銹鋼	304
91	柱銷	不銹鋼	304
92	密封圈	NBR	

\*AISI 316 不銹鋼深井泵可以按需求提供。





STAIRS PUMPS

# 產品數據

結構圖：SP-500

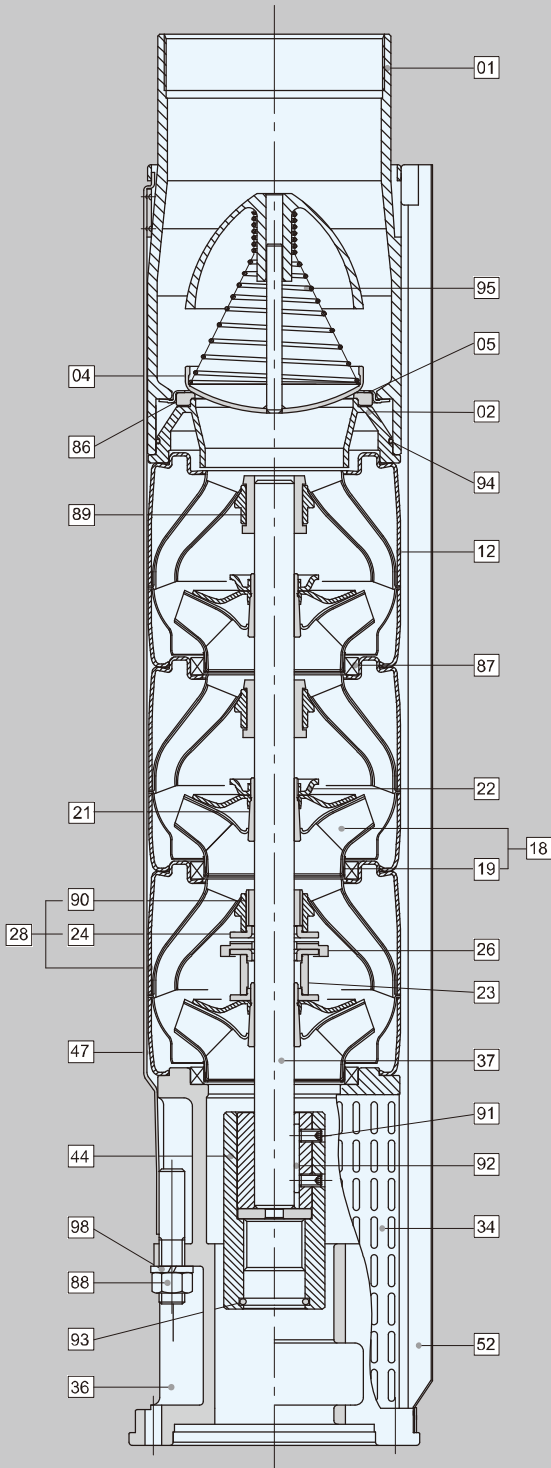

## 材質說明-8"深井泵

位置	名稱	材質	AISI
01	出水腔	不銹鋼	304
02	閥座底部保持器	不銹鋼	304
04	杯閥	不銹鋼	304
05	閥座頂部保持器	不銹鋼	304
12	導輪	不銹鋼	304
18	葉輪	不銹鋼	304
19	葉輪頸環	不銹鋼	304
21	錐套	不銹鋼	304
22	錐套螺母	不銹鋼	304
23	止水環螺母	不銹鋼	304
24	止水環	不銹鋼	304
26	止水環間隔墊圈	碳 石墨/PTFE	
28	底部導輪	不銹鋼	304
34	過濾器	不銹鋼	304
36	支架	不銹鋼	304
37	泵軸	不銹鋼	431
44	聯接器	不銹鋼	304
47	緊固帶	不銹鋼	304
52	纜護套	不銹鋼	304
86	閥座	NBR	
87	頸環	SUS304+NBR	
88	螺母	不銹鋼	304
89	軸承	NBR	
90	軸承	NBR+SUS304	
91	螺栓	不銹鋼	304
92	柱銷	不銹鋼	304
93	密封圈	NBR	
94	密封圈	NBR	
95	彈簧	不銹鋼	304
98	彈簧墊圈	不銹鋼	304

\*AISI 316 不銹鋼深井泵可以按需求提供。



STAIRS PUMPS

# 產品數據

結構圖：SP-1100

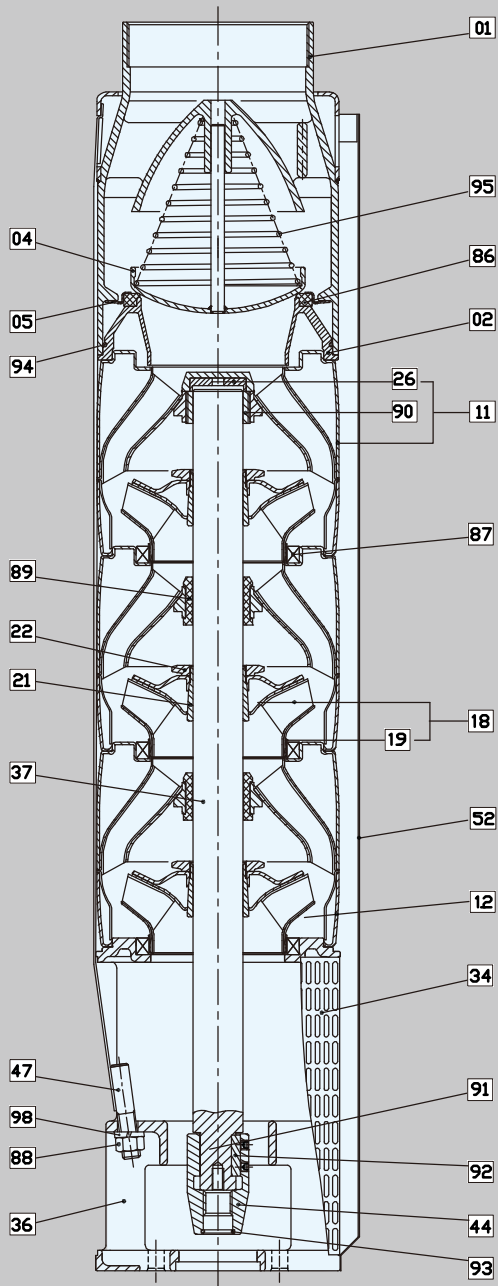

## 材質說明-10"深井泵

位置	名稱	材質	AISI
01	出水腔	不銹鋼	304
02	閥座底部保持器	不銹鋼	304
04	杯閥	不銹鋼	304
05	閥座頂部保持器	不銹鋼	304
11	頂部導輪	不銹鋼	304
+26	止水環間隔墊圈	碳纖維+MoS2+PTFE	
+90	頂部軸承	SUS304+NBR	
12	導輪	不銹鋼	304
18	葉輪	不銹鋼	304
18	葉輪-A	不銹鋼	304
+19	葉輪頸環	不銹鋼	304
21	錐套	不銹鋼	304
22	錐套螺母	不銹鋼	304
34	濾網-單導綫	不銹鋼	304
34	濾網-雙導綫	不銹鋼	304
36	支架-6"	不銹鋼	304
36	支架-8"	不銹鋼	304
37	泵軸	不銹鋼	431
44	連接器-6"	不銹鋼	304
44	連接器-8"	不銹鋼	304
47	緊固帶	不銹鋼	304
52	綫纜護套	不銹鋼	304
86	閥座	NBR	70
87	頸環	PPS+NBR	
88	螺母	不銹鋼	304
89	軸承	NBR	70
91	螺栓-6"	不銹鋼	304
91	螺栓-8"	不銹鋼	304
92	柱銷-6"	不銹鋼	304
92	柱銷-8"	不銹鋼	304
93	密封圈-6"	NBR	70
93	密封圈-8"	NBR	70
94	密封圈	NBR	70
95	彈簧	不銹鋼	304
98	彈簧墊圈	不銹鋼	304

\*AISI 316 不銹鋼深井泵可以按需求提供。



## 4"不銹鋼深井泵

斯特尔SP4"系列深井泵采用高品質耐腐蝕，耐磨損不銹鋼材料，通過先進的工業設計技術開發制造。

SP4"深井泵優异的性能和堅固的結構可以滿足在最嚴苛的工作條件下高效率，長壽命運行。

流量 (m<sup>3</sup>/h) : 0.3~18

最大揚程 (m) : 285

### 應用領域

- ◆ 深井飲用水提取
- ◆ 農業灌溉，牲畜飲水等
- ◆ 市政和工業供水
- ◆ 液體增壓
- ◆ 噴泉等

### 輸送液體

- ◆ 非易燃易爆，潔淨之液體

### 運行條件

- ◆ 最大環境溫度 (液體) : 30°C
- ◆ 最大含沙量: 50g/m<sup>3</sup>

### 產品特點

- ◆ 全不銹鋼結構設計制造，長時間無故障運行
- ◆ 所有金屬部件均為304不銹鋼，泵軸采用431高強度不銹鋼
- ◆ 重負荷止回閥出水腔設計，長壽命，易安裝
- ◆ 方便安全的吊鉤設計
- ◆ 安裝說明符合NEMA標準
- ◆ 高品質軸承保證低摩擦，高耐磨
- ◆ 重負荷葉輪，導輪保證最佳性能
- ◆ 不銹鋼過濾器有效阻止沙粒或其他異物進入

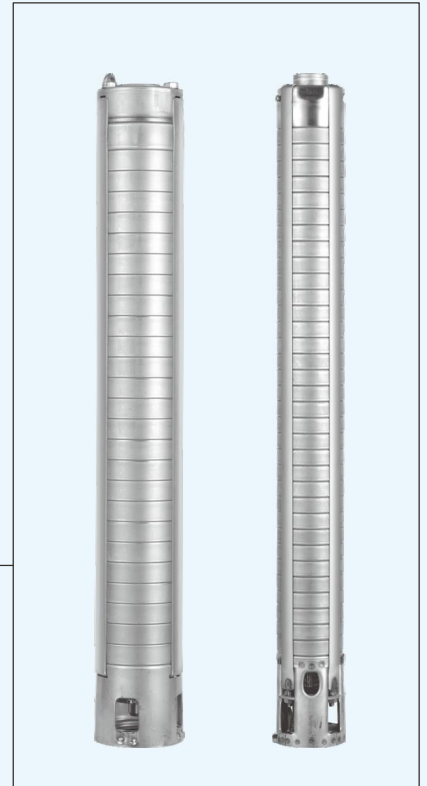

## 6"不銹鋼深井泵

斯特尔SP6"系列深井泵采用高品質的耐腐蝕304或316不銹鋼材料，泵軸采用高強度431不銹鋼。可靠的性能可以保證SP6"系列深井泵高效率，長時間無故障運行。重量輕，堅固的結構適用于重負荷應用。

流 量 ( m<sup>3</sup>/h ) : 3~78

最大揚程 ( m ) : 433

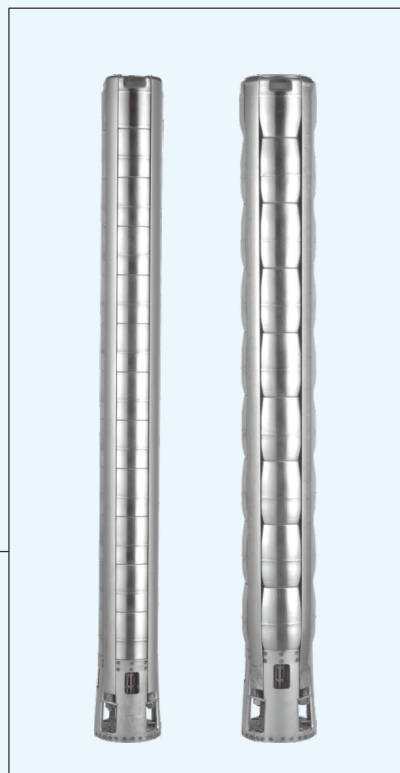

### 應用領域

- ◆ 深井飲用水提取
- ◆ 農業灌溉和牲畜飲水
- ◆ 市政和工業供水
- ◆ 液體增壓
- ◆ 礦山排水
- ◆ 噴泉，等

### 輸送液體

- ◆ 非易燃易爆，潔淨之液體

### 運行條件

- ◆ 最大環境溫度 ( 液體 ) : 30℃
- ◆ 最大含沙量: 50g/m<sup>3</sup>

### 產品特點

- ◆ 全不銹鋼結構設計制造，長時間無故障運行
- ◆ 重負荷止回閥出水腔設計，長壽命，易安裝
- ◆ 安裝說明符合NEMA標準
- ◆ 高品質軸承保證低摩擦，高耐磨
- ◆ 重負荷葉輪，導輪保證最佳的性能
- ◆ 不銹鋼過濾器有效阻止沙粒或其它異物進入



## 8"不銹鋼深井泵

斯特尔SP8"系列深井泵適合重負荷，大流量應用。高效率的水力學葉輪，導輪設計，有效降低能耗，保證在嚴苛的條件下長時間，可靠運行。

流 量 (m<sup>3</sup>/h) : 12~120

最大揚程 (m) : 412

### 應用領域

- ◆ 市政供水
- ◆ 城市水處理
- ◆ 工業冷卻，清洗和生產
- ◆ 農業灌溉等
- ◆ 高樓增壓供水等
- ◆ 礦山排水
- ◆ 噴泉等

### 輸送液體

- ◆ 非易燃易爆，潔淨之液體

### 運行條件

- ◆ 最大環境溫度 (液體) : 30°C
- ◆ 最大含沙量: 50g/m<sup>3</sup>

### 產品特點

- ◆ 高效率泵浦設計有效降低能源消耗，為客戶節省運行成本
- ◆ 適用於嚴苛的工作條件
- ◆ 採用高品質的材料和30多年的製造技術基礎，確保優異的品質
- ◆ 所有的金屬部件均為304不銹鋼，泵軸採用高強度431不銹鋼
- ◆ 高強度的431不銹鋼泵軸耐機械磨損，耐腐蝕
- ◆ 重負荷止回閥出水腔設計，長壽命，易安裝
- ◆ 高剛性不銹鋼聯軸器使泵軸和馬達的安裝更簡便，保證同軸度
- ◆ 安裝說明符合NEMA標準



# 10"不銹鋼深井泵

斯特尔SP10"系列深井泵適合重負荷，大流量應用，高效率的水力學葉輪，導輪設計，有效降低能耗，保證在嚴苛的條件下長時間，可靠運行。

流 量 ( m<sup>3</sup>/h ) : 16~280

最大揚程 ( m ) : 502

## 應用領域

- ◆ 市政供水
- ◆ 城市水處理
- ◆ 工業冷卻，清洗和生產
- ◆ 農業灌溉等
- ◆ 高樓增壓供水等
- ◆ 礦山排水
- ◆ 噴泉等

## 輸送液體

- ◆ 非易燃易爆，潔淨之液體

## 運行條件

- ◆ 最大環境溫度 ( 液體 ) : 30℃
- ◆ 最大含沙量: 50g/m<sup>3</sup>

## 產品特點

- ◆ 高效率泵浦設計有效降低能源消耗，為客戶節省運行成本
- ◆ 適用於嚴苛的工作條件
- ◆ 採用高品質的材料和30多年的製造技術基礎，確保優異的品質
- ◆ 所有的金屬部件均為304不銹鋼，泵軸採用 高強度431不銹鋼
- ◆ 高強度的431不銹鋼泵軸耐機械磨損，耐腐蝕
- ◆ 重負荷止回閥出水腔設計，長壽命，易安裝
- ◆ 高剛性不銹鋼聯軸器使泵軸和馬達的安裝更簡便，保證同軸度
- ◆ 安裝說明符合NEMA標準

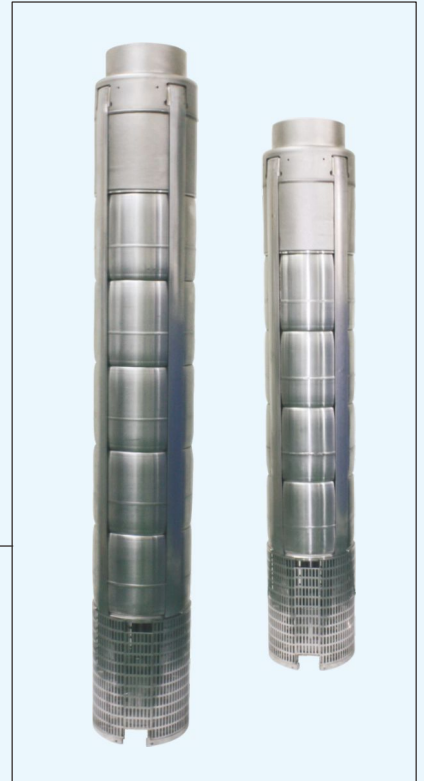



# Stairs SP Series

性能曲綫 **SPO**

SP 4"

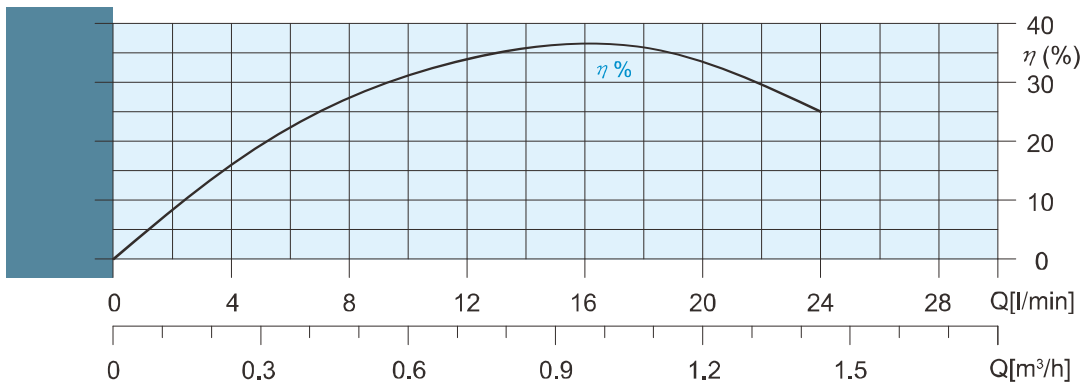
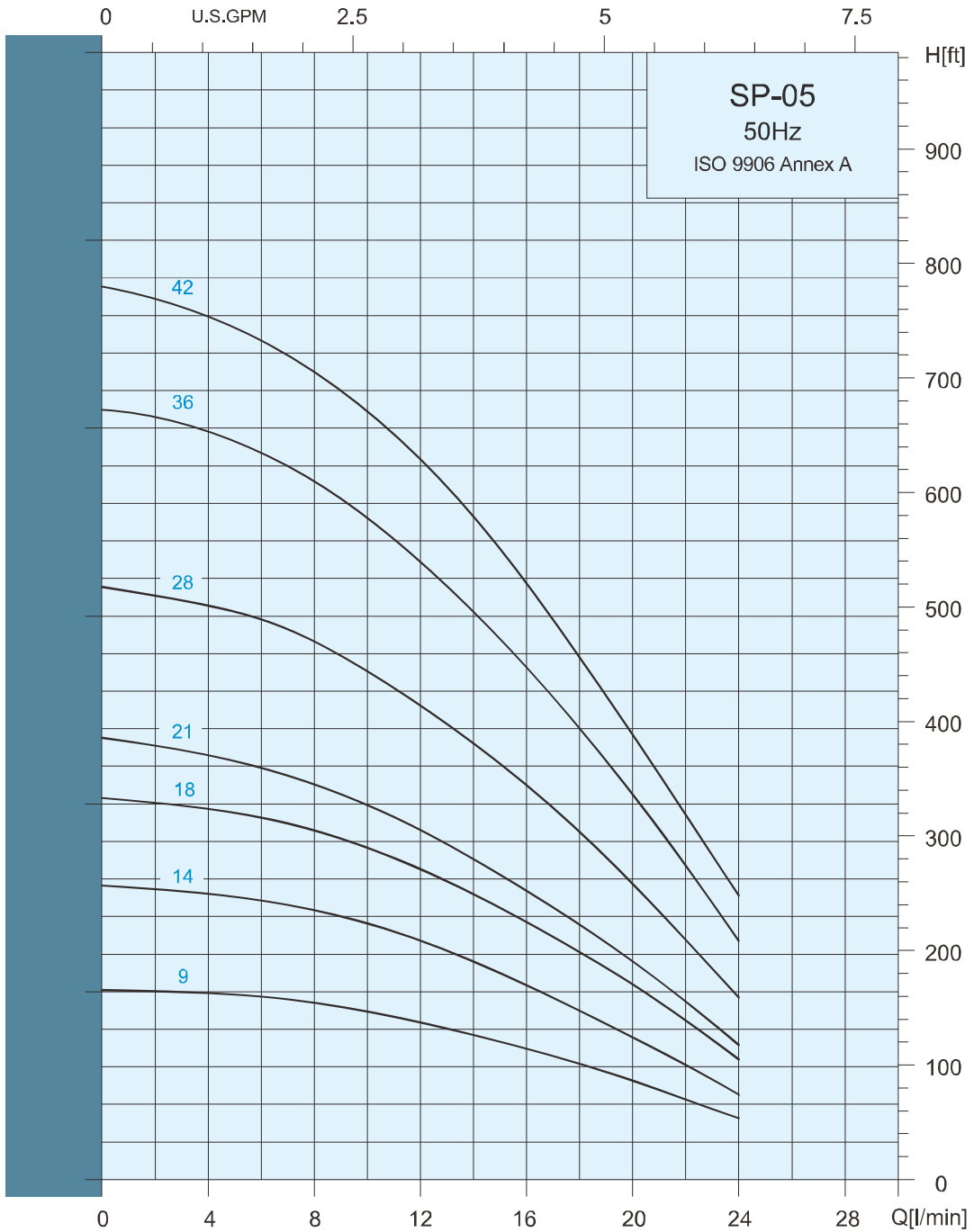

### 選型數據

Pump Type	STAGES	KW	HP	Q capacity 2900 rpm																
				l/min	5	10	15	20	25	30	35	40	45	50	60	70	80	90	100	120
				m <sup>3</sup> /h	0.3	0.6	0.9	1.2	1.5	1.8	2.1	2.4	2.7	3.0	3.6	4.2	4.8	5.4	6.0	7.2
				H = TOTAL HEAD IN METERS																
SP-0509	9	0.37	0.5	52	48	45	36	27	14											
SP-0514	14	0.37	0.5	79	76	68	56	38	21											
SP-0518	18	0.55	0.75	102	96	88	72	52	27											
SP-0521	21	0.55	0.75	118	112	100	81	58	30											
SP-0528	28	0.75	1.0	158	153	138	111	78	42											
SP-0536	36	1.1	1.5	205	195	175	134	103	54											
SP-0542	42	1.1	1.5	238	235	203	167	118	67											

\*更高壓力，最大段數至57段的產品可以按需求提供

### 尺寸和重量

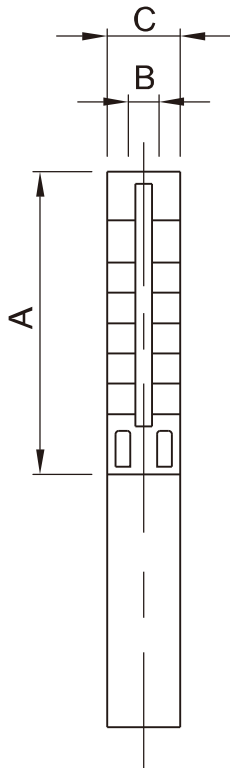

Pump Type	Dimensions(mm)			Net Weight(Kg)
	A	B	C	Pump
SP-0509	356	RP/NPT 1 1/4"	98	2.9
SP-0514	461		98	3.7
SP-0518	545		98	4.4
SP-0521	608		98	5.0
SP-0528	755		98	6.2
SP-0536	946		98	9.9
SP-0542	1072		98	11.3

C=泵的最大直徑包含纜纜護套和馬達





# Stairs SP Series

## 性能曲綫 SP10

SP 4"

0 U.S.GPM 2.5 5 7.5 10 12.5

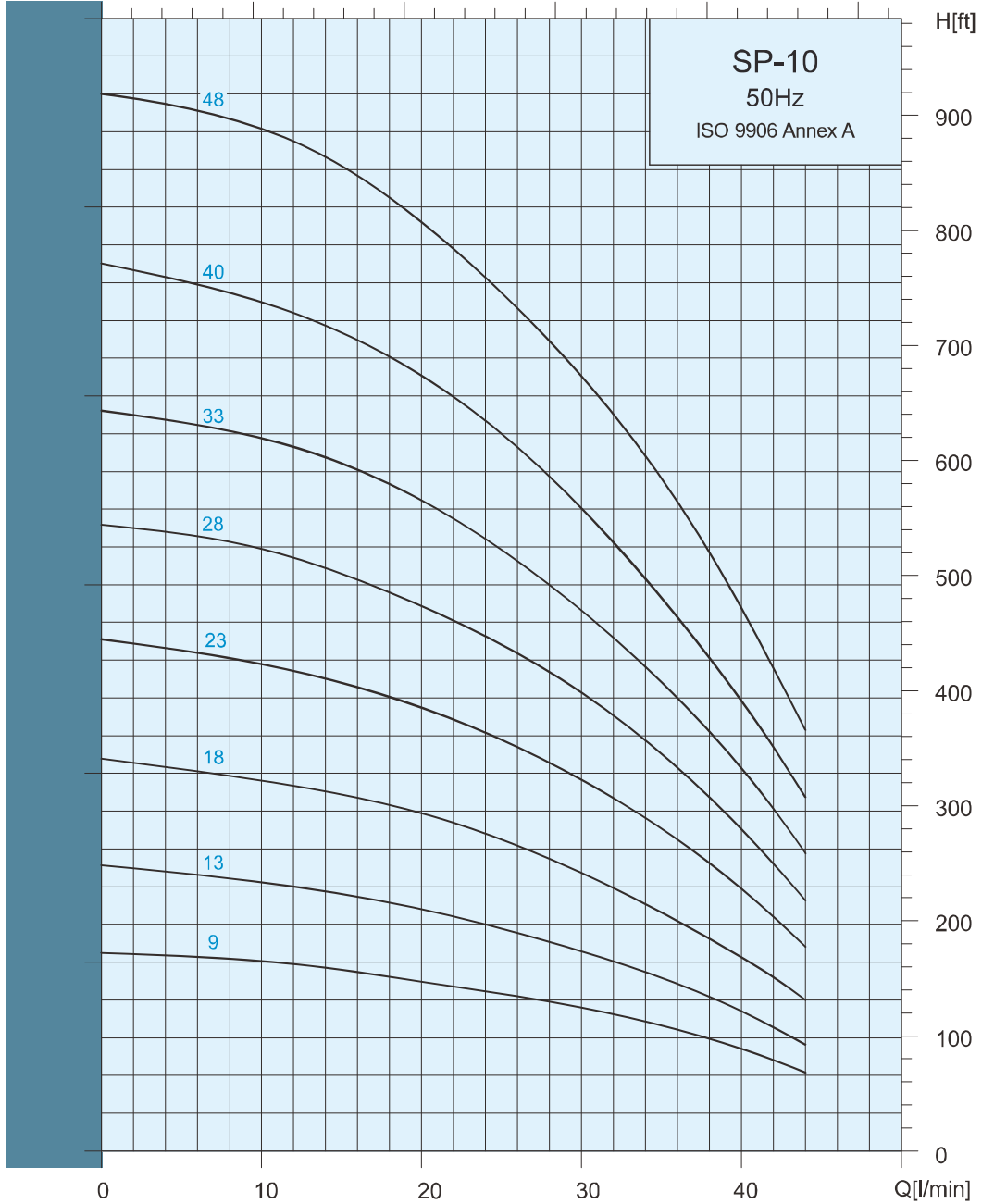

0 10 20 30 40 Q[l/min]

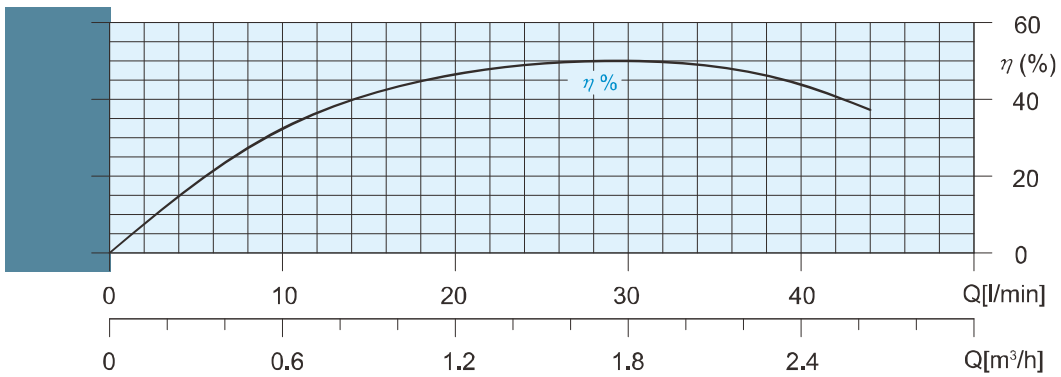

0 10 20 30 40 Q[l/min]  
0 0.6 1.2 1.8 2.4 Q[m³/h]

### 選型數據

Pump Type	STAGES	KW	HP	Q capacity 2900 rpm																
				l/min	0	5	10	15	20	25	30	35	40	45	50	60	70	80	90	100
				m <sup>3</sup> /h	0	0.3	0.6	0.9	1.2	1.5	1.8	2.1	2.4	2.7	3.0	3.6	4.2	4.8	5.4	6.0
H =TOTAL HEAD IN METERS																				
SP-1009	9	0.37	0.5	53			48	45	42	38	33	26								
SP-1013	13	0.55	0.75	77			68	64	58	54	46	38								
SP-1018	18	0.75	1.0	104			94	89	83	74	64	51								
SP-1023	23	1.1	1.5	136			124	118	108	98	84	69								
SP-1028	28	1.5	2.0	166			154	145	134	122	105	86								
SP-1033	33	1.5	2.0	195			183	173	159	143	124	102								
SP-1040	40	2.2	3.0	235			218	205	190	170	147	119								
SP-1048	48	2.2	3.0	280			261	246	228	204	178	143								

\*更高壓力，最大段數至90段的產品可以按需求提供

### 尺寸和重量

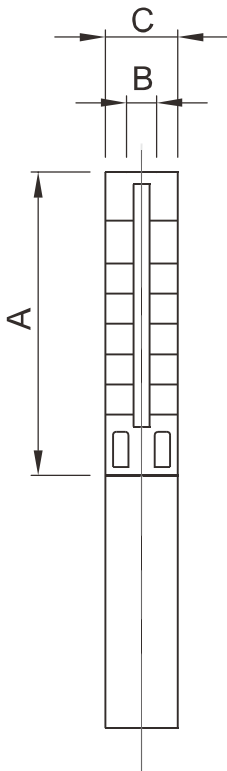

Pump Type	Dimensions(mm)			Net Weight(Kg)
	A	B	C	Pump
SP-1009	356	RP/NPT 1 1/4"	98	3.0
SP-1013	440		98	3.8
SP-1018	545		98	4.7
SP-1023	650		98	5.7
SP-1028	755		98	6.6
SP-1033	883		98	9.7
SP-1040	1030		98	11.5
SP-1048	1198		98	13.5

C=泵的最大直徑包含纜纜護套和馬達



# Stairs SP Series

## 性能曲綫 SP18

SP 4"

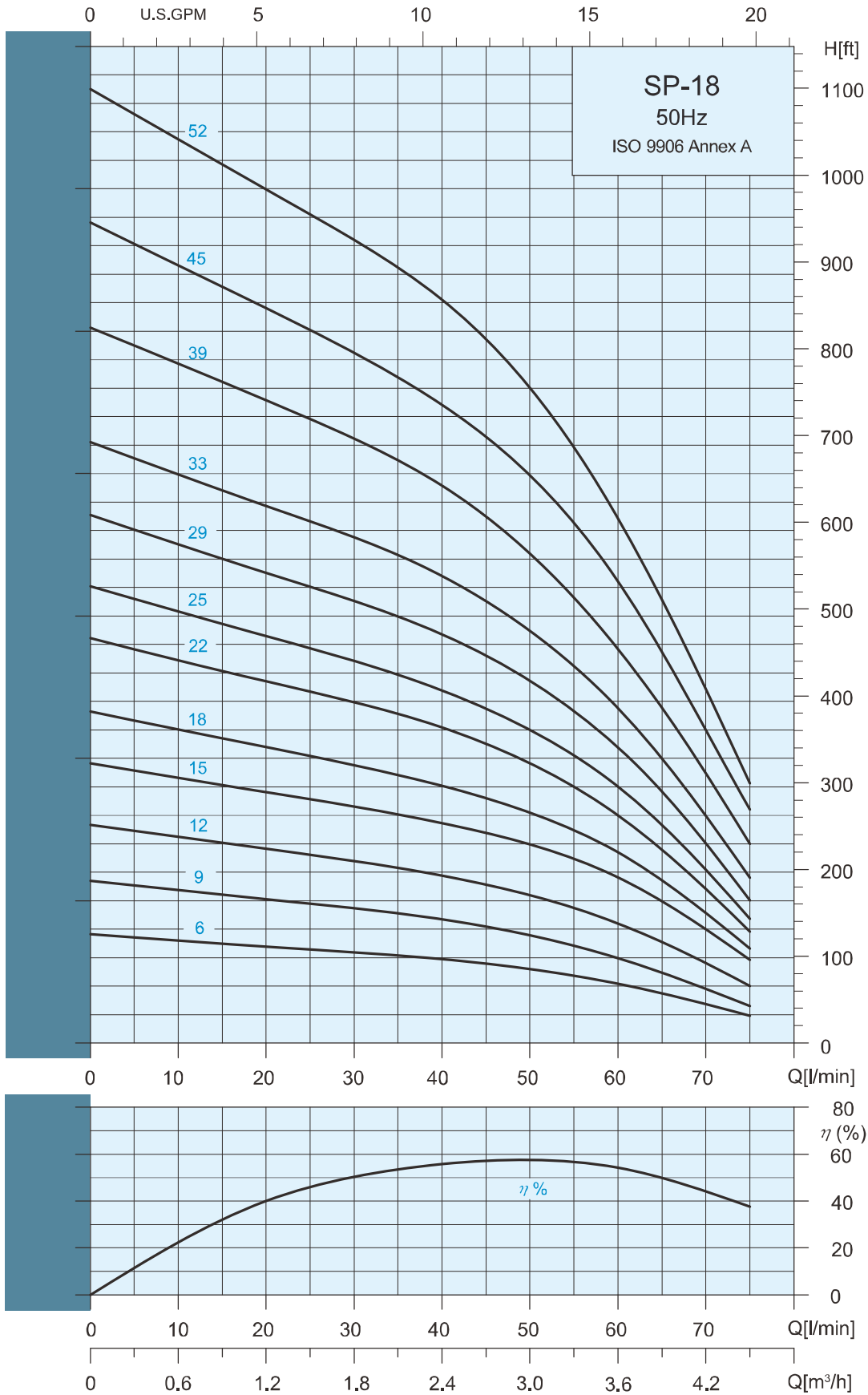







# Stairs SP Series

## 性能曲綫 SP25

SP 4"

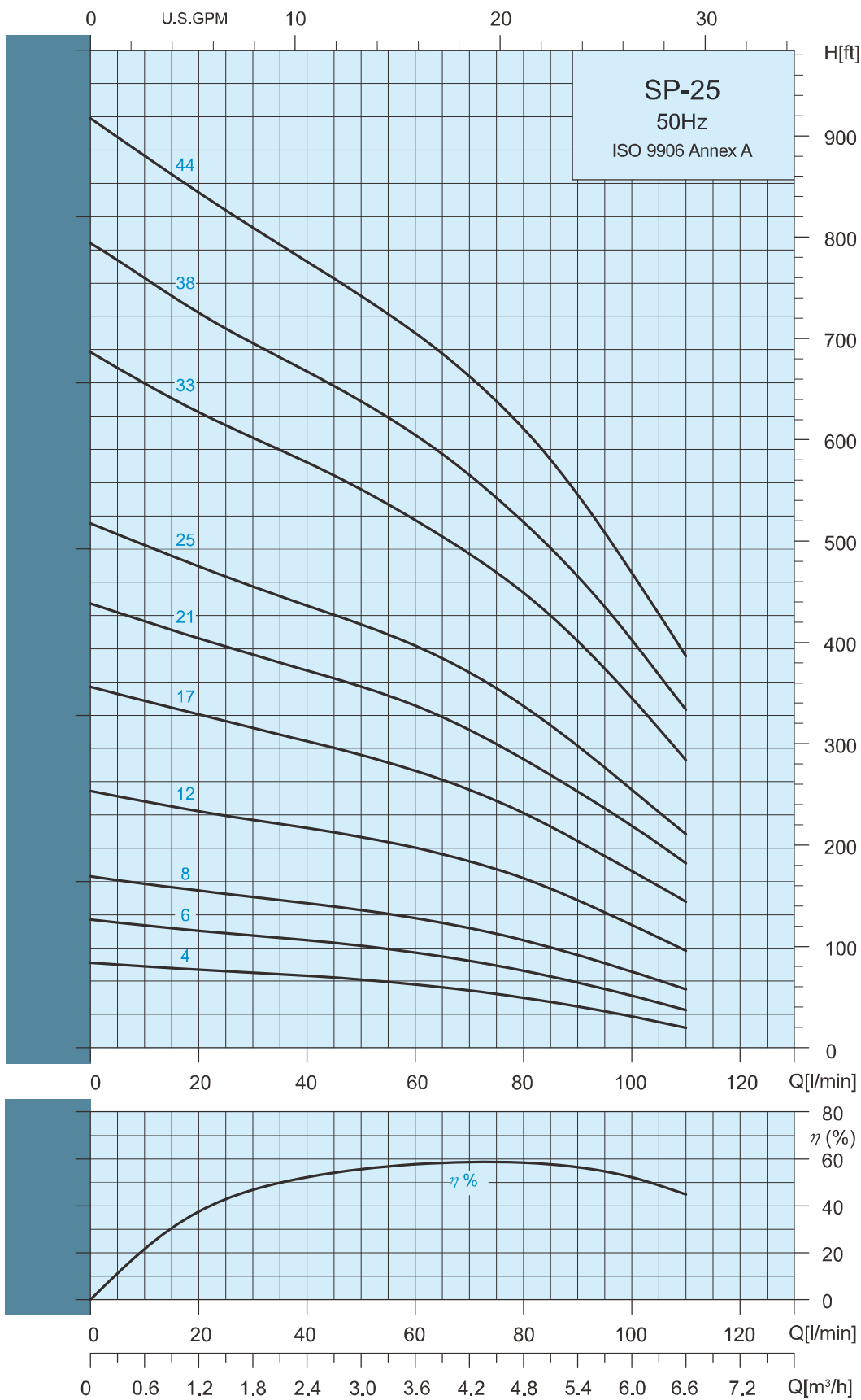

### 選型數據

Pump Type	STAGES	KW	HP	Q capacity 2900 rpm																
				l/min	15	20	25	30	35	40	45	50	60	70	80	90	100	120	140	160
				m <sup>3</sup> /h	0.9	1.2	1.5	1.8	2.1	2.4	2.7	3.0	3.6	4.2	4.8	5.4	6.0	7.2	8.4	9.6
H = TOTAL HEAD IN METERS																				
SP-2504	4	0.37	0.5	25				23	22	21	20.5	20	19	17	15	13	10			
SP-2506	6	0.55	0.75	38				34	33	32	31	30	28	26	24	20	16			
SP-2508	8	0.75	1.0	52				45	44	43	42	41	39	36	33	28	23			
SP-2512	12	1.1	1.5	77				68	67	66	64	63	60	56	50	44	37			
SP-2517	17	1.5	2.0	108				96	94	93	90	88	84	77	70	63	54			
SP-2521	21	2.2	3.0	134				118	115	113	111	108	103	96	87	77	67			
SP-2525	25	2.2	3.0	157				138	136	133	129	127	121	113	103	90	78			
SP-2533	33	3.0	4.0	209				184	180	176	172	168	159	149	137	123	105			
SP-2538	38	4.0	5.5	242				212	208	204	199	194	185	172	158	142	123			
SP-2544	44	4.0	5.5	279				247	242	237	231	226	215	202	187	166	143			

\*更高壓力，最大段數至85段的產品可以按需求提供

### 尺寸和重量

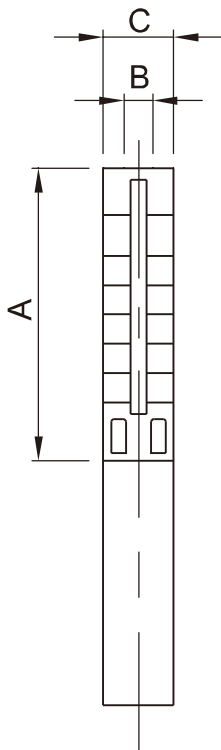

Pump Type	Dimensions(mm)			Net Weight(Kg)
	A	B	C	Pump
SP-2504	251	RP/NPT 1 1/2"	98	2.0
SP-2506	293		98	2.4
SP-2508	335		98	2.8
SP-2512	419		98	3.6
SP-2517	524		98	4.5
SP-2521	608		98	5.3
SP-2525	692		98	6.0
SP-2533	868		98	9.6
SP-2538	973		98	10.9
SP-2544	1099		98	12.4

C=泵的最大直徑含纜纜護套和馬達

性能曲綫 **SP40**

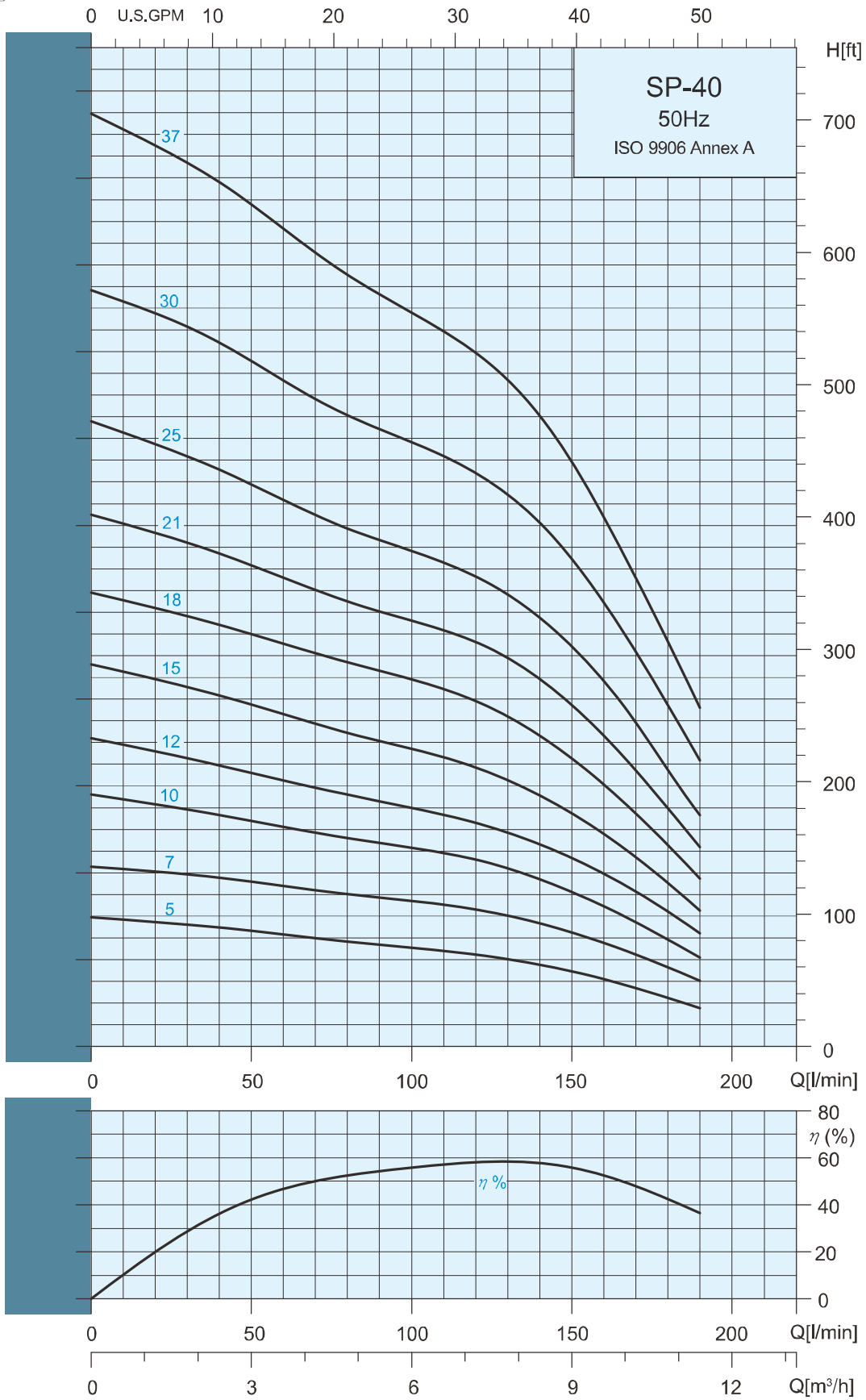

### 選型數據

Pump Type	STAGES	KW	HP	Q capacity 2900 rpm																	
				l/min	30	35	40	45	50	60	70	80	90	100	120	140	160	180	200	250	300
				m <sup>3</sup> /h	1.8	2.1	2.4	2.7	3.0	3.6	4.2	4.8	5.4	6.0	7.2	8.4	9.6	10.8	12	15	18
H = TOTAL HEAD IN METERS																					
SP-4005	5	0.75	1.0	30			28	27	26	26	25	24	23	22	21	19	15	12			
SP-4007	7	1.1	1.5	41			38	37	36	36	35	35	34	34	32	27	24	17			
SP-4010	10	1.5	2.0	58			54	53	52	51	49	47	47	46	43	38	32	25			
SP-4012	12	2.2	3.0	71			65	64	63	61	60	58	57	55	52	47	40	31			
SP-4015	15	2.2	3.0	87			80	79	78	76	74	72	70	68	64	57	49	38			
SP-4018	18	3.0	4.0	104			98	96	95	93	90	88	86	84	79	72	60	47			
SP-4021	21	4.0	5.5	122			114	113	111	107	105	102	100	98	93	85	72	55			
SP-4025	25	4.0	5.5	144			133	131	128	126	123	119	116	114	107	97	84	64			
SP-4030	30	5.5	7.5	174			163	160	157	154	149	145	142	139	131	120	103	79			
SP-4037	37	5.5	7.5	215			199	196	194	188	183	177	173	169	160	145	122	93			

\*更高壓力，最大段數至110段的產品可以按需求提供

### 尺寸和重量

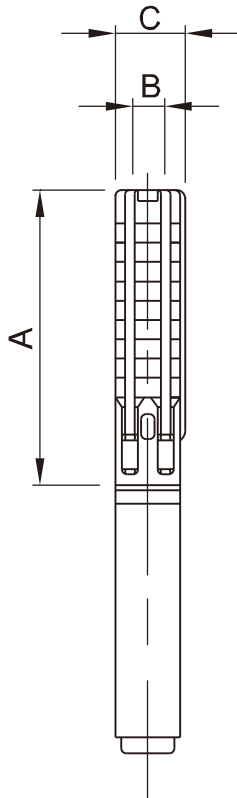

Pump Type	Dimensions(mm)			Net Weight(Kg)
	A	B	C	Pump
SP-4005	412	RP/NPT 2"	98	4.3
SP-4007	496		98	5.3
SP-4010	622		98	6.8
SP-4012	706		98	7.8
SP-4015	832		98	9.3
SP-4018	958		98	10.8
SP-4021	1084		98	12.3
SP-4025	1252		98	14.3
SP-4030	1462		98	16.8
SP-4037	1753		98	20.3

C=泵的最大直徑含纜纜護套和馬達





# Stairs SP Series

## 性能曲綫 SP70

SP 4"

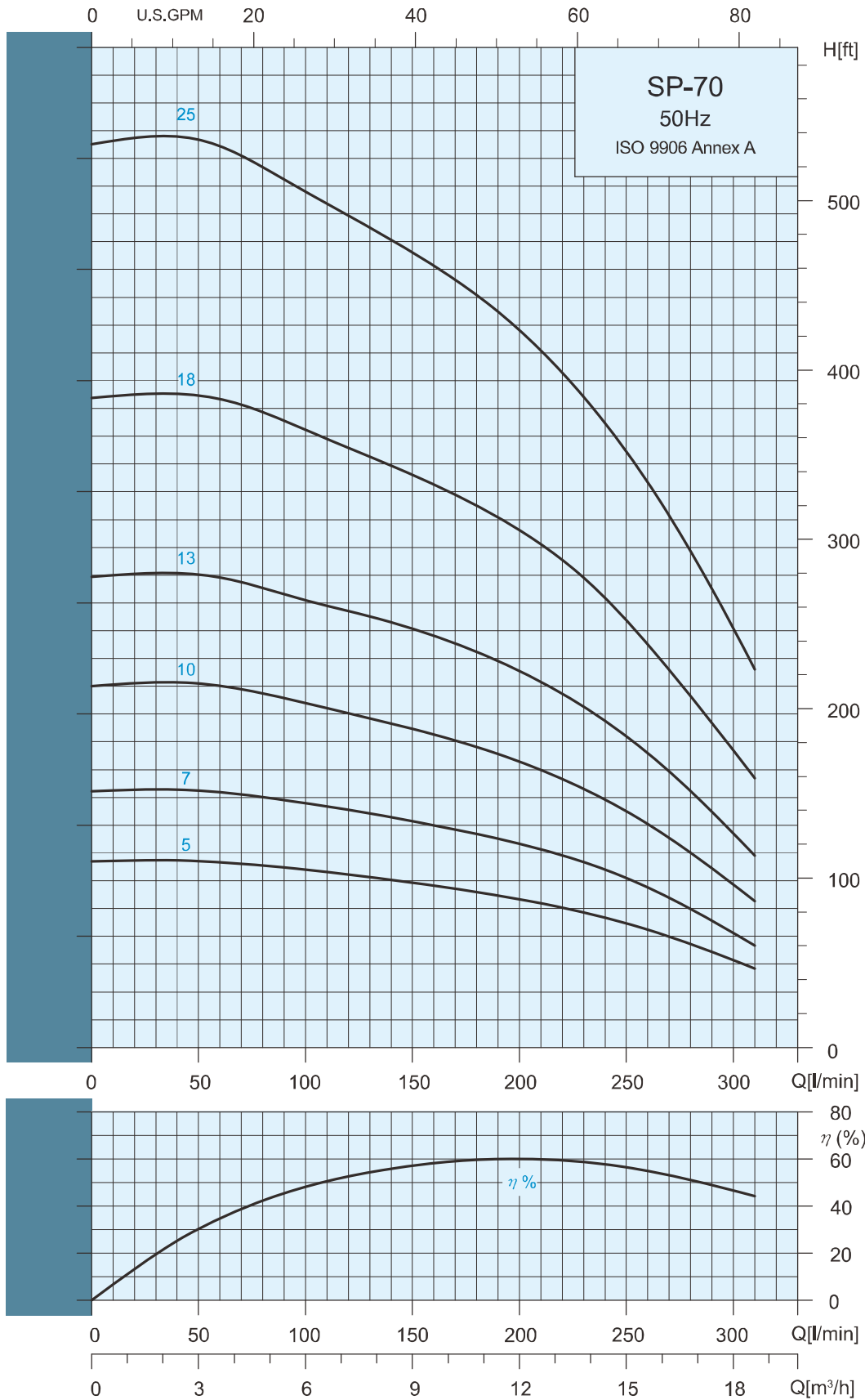

### 選型數據

Pump Type	STAGES	KW	HP	Q capacity 2900 rpm															
				l/min	70	80	90	100	120	140	160	180	200	250	300	320	340	360	380
				m <sup>3</sup> /h	4.2	4.8	5.4	6.0	7.2	8.4	9.6	10.8	12	15	18	19	20	22	23
H = TOTAL HEAD IN METERS																			
SP-7005	5	1.5	2.0	33				32	31	30	28	27	26	22	16				
SP-7007	7	2.2	3.0	46				44	43	42	40	37	36	30	20				
SP-7010	10	3.0	4.0	65				62	60	58	57	54	52	43	29				
SP-7013	13	4.0	5.5	84				80	78	77	74	72	67	56	38				
SP-7018	18	5.5	7.5	117				111	108	104	102	97	93	77	54				
SP-7025	25	7.5	10	163				154	149	145	141	135	129	107	75				

### 尺寸和重量

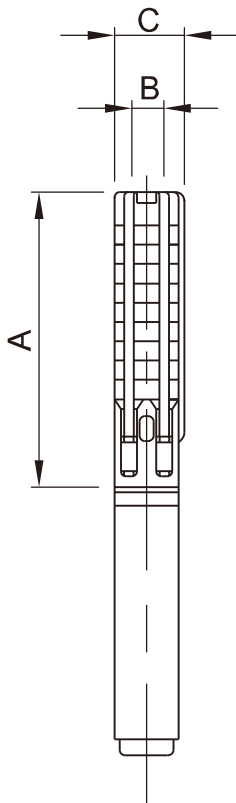

Pump Type	Dimensions(mm)			Net Weight(Kg)
	A	B	C	Pump
SP-7005	505	RP/NPT 2"	98	5.0
SP-7007	635		98	6.3
SP-7010	830		98	8.2
SP-7013	1025		98	10.2
SP-7018	1350		98	13.4
SP-7025	1805		98	17.8

C=泵的最大直徑含纜纜護套和馬達



# Stairs SP Series



## 性能曲綫 **SP90** SP 6"

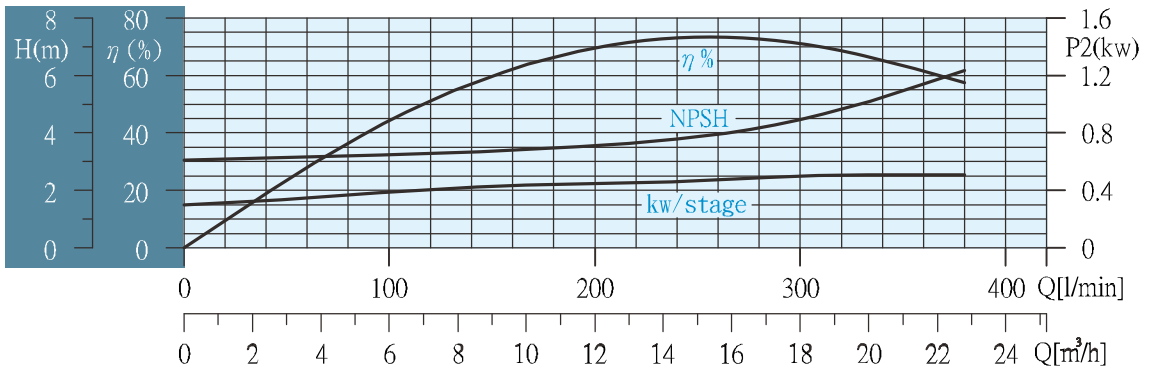
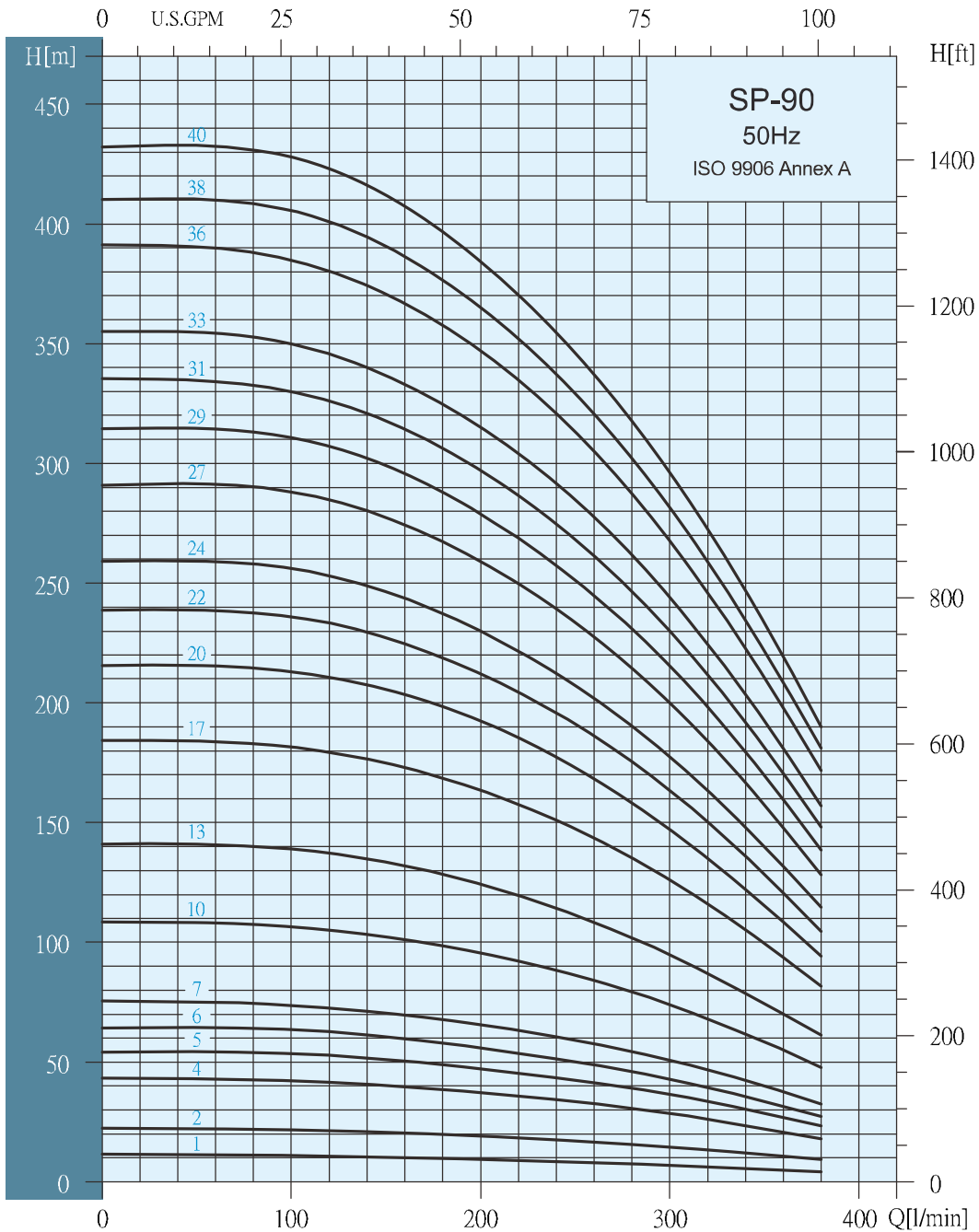



STAIRS PUMPS

選型數據

Pump Type	Motor		Max.current		m³/h l/min	Q capacity 2900 rpm							
	P2		Amp			3	6	9	12	15	18	21	23
	KW	HP	220V	380V		50	100	150	200	250	300	350	383
SP 90-1	0.55	0.75	2.6	1.5	HEAD IN METERS	11.5	11	10.5	9.5	8	7	6	4
SP 90-2	1.1	1.5	5.2	3.0		22	21.5	20	19	17.5	14	12	9
SP 90-4	2.2	3	9.5	5.5		42.5	42	40	38	33	28.5	23	18
SP 90-5	3	4	13.3	7.7		53	52	50.5	47.5	42.5	37	28.5	22
SP 90-6	3.7	5	15.4	8.9		64	63	60	56	50	43	34	27
SP 90-7	4	5.5	17	10.4		75	74	70	66	59	50.5	40	32
SP 90-10	5.5	7.5	22.2	12.8		108	107	102	95	86	74	58	48
SP 90-13	7.5	10	28.5	16.5		141	139	133	124	112	95	75	60
SP 90-17	9.3	12.5	36	20.9		184	182	175	163	147	126	100	80
SP 90-20	11	15	41.8	24.2		216	213	206	192	173	147	116	95
SP 90-22	13	17.5	50	29		239	237	228	212	190	163	129	105
SP 90-24	13	17.5	50	29		260	257	247	230	208	178	140	115
SP 90-27	15	20	55	32		291	288	277	259	234	200	158	128
SP 90-29	18.5	25	69	40		314	311	300	279	250	215	170	138
SP 90-31	18.5	25	69	40		335	330	318	298	269	230	181	148
SP 90-33	18.5	25	69	40		355	350	337	315	285	243	191	157
SP 90-36	22	30	81	47		390	385	371	348	313	268	210	170
SP 90-38	22	30	81	47		410	405	390	365	330	281	222	180
SP 90-40	22	30	81	47		433	428	412	384	346	296	235	190

\*更高壓力，最大段數至60段的產品可以按需求提供

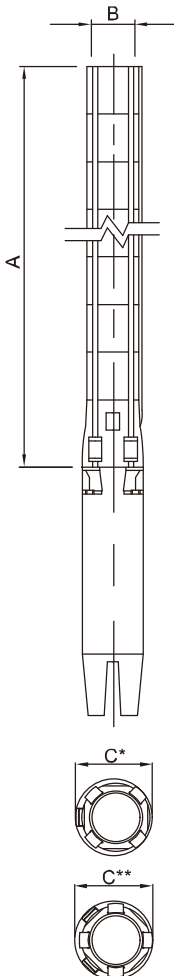

尺寸和重量

Pump Type	Dimensions(mm)				Net Weight(Kg)
	A	B	C*	C**	Pump
SP 90-1	343	RP 2 1/2" NPT 3"	131		5.0
SP 90-2	403		131		6.4
SP 90-4	524		131		9.3
SP 90-5	585		131		10.8
SP 90-6	645		131		12.2
SP 90-7	706		131		13.7
SP 90-10	887		131		18.0
SP 90-13	1069		142	142	22.4
SP 90-17	1311		142	142	28.2
SP 90-20	1492		142	142	32.5
SP 90-22	1613		142	142	35.4
SP 90-24	1734		142	142	38.3
SP 90-27	1916		142	142	42.7
SP 90-29	2037		142	142	45.6
SP 90-31	2158		142	142	48.5
SP 90-33	2279		142	142	51.4
SP 90-36	2460		142	142	55.7
SP 90-38	2581		142	142	58.6
SP 90-40	2702		142	142	61.5

C\*: 泵的最大直徑包含1個纜纜護套  
C\*\*: 泵的最大直徑包含2個纜纜護套



# Stairs SP Series

## 性能曲綫 SP150

SP 6"

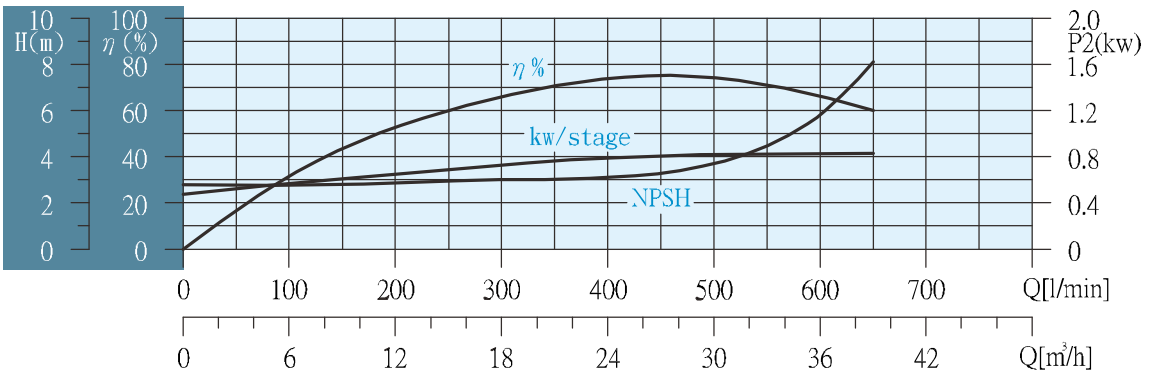
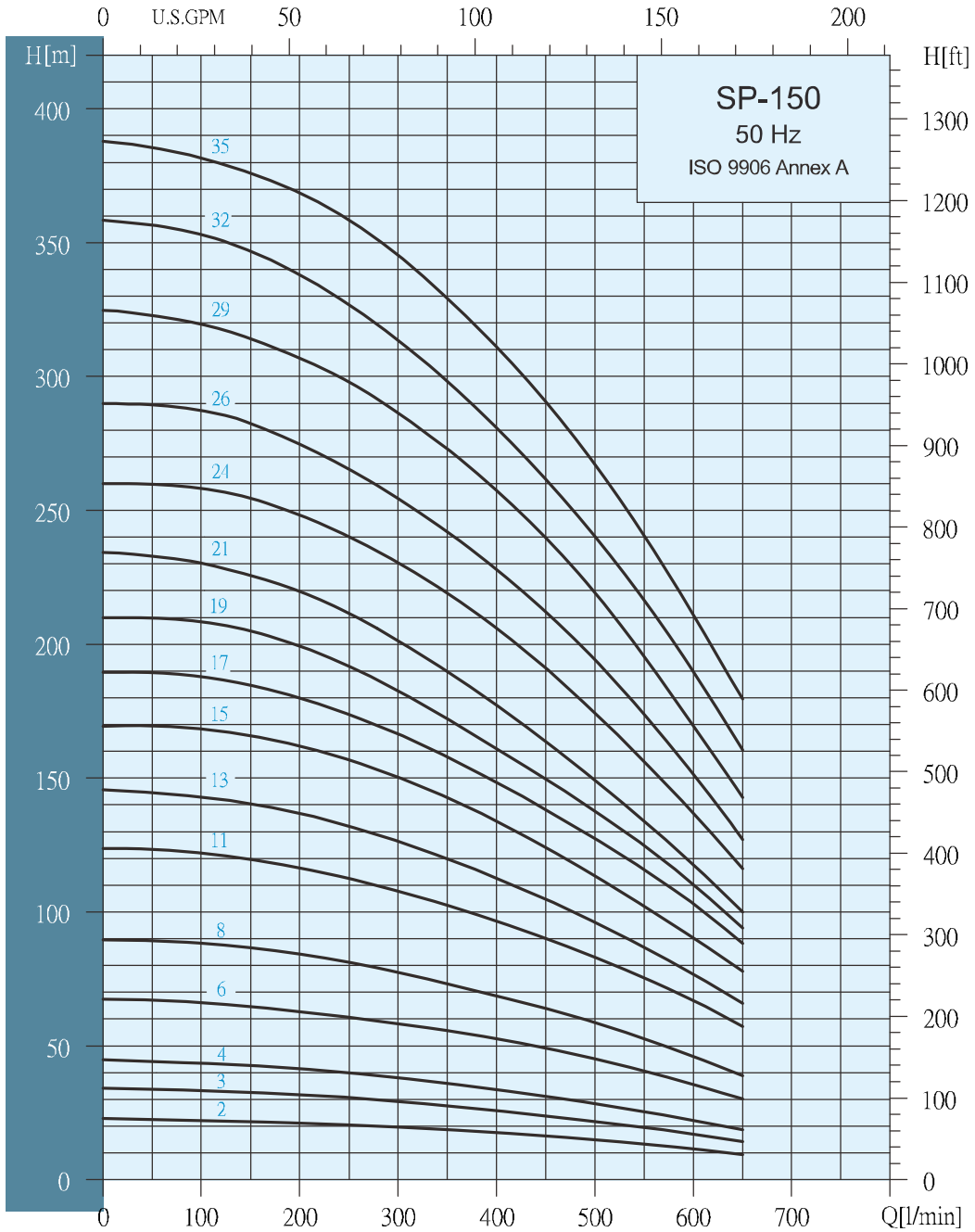





STAIRS PUMPS

選型數據

Pump Type	Motor		Max.current		m <sup>3</sup> /h l/min	Q capacity 2900 rpm												
	P2		Amp			6	9	12	15	18	21	24	27	30	33	36	39	42
	KW	HP	220V	380V		100	150	200	250	300	350	400	450	500	550	600	650	700
SP150-2	2,2	3	9,5	5,5	HEAD IN METERS	23	22	21	20	19	18	17	16	15	13	11	9	6
SP150-3	3	4	13,3	7,7		33	32	31	30	29	28	26	24	22	20	17	14	11
SP150-4	3,7	5	15,4	8,9		43	42	41	40	38	36	34	31	28	26	23	19	15
SP150-6	5,5	7,5	22,2	12,8		67	64	62	60	58	56	52	49	45	40	36	30	25
SP150-8	7,5	10	28,5	16,5		88	87	84	81	78	73	68	64	58	53	46	38	31
SP150-11	11	15	41,8	24,2		122	120	117	112	108	102	97	90	83	76	67	57	47
SP150-13	11	15	41,8	24,2		143	140	137	132	127	120	113	105	97	87	77	66	55
SP150-15	15	20	55	32		168	166	162	157	150	142	134	124	113	102	90	77	65
SP150-17	15	20	55	32		188	185	180	173	167	158	148	138	127	116	103	88	71
SP150-19	18,5	25	69	40		208	205	199	192	182	172	161	150	137	125	110	94	77
SP150-21	18,5	25	69	40		230	226	220	212	202	190	177	164	149	134	117	100	80
SP150-24	22	30	81	47		258	254	248	240	230	219	207	191	175	156	137	117	93
SP150-26	22	30	81	47		287	282	275	266	255	242	227	212	194	173	152	127	100
SP150-29	26	35	96	56		319	314	307	298	287	273	257	240	220	196	170	143	113
SP150-32	30	40	111	64		353	347	338	327	313	298	281	261	240	217	190	160	130
SP150-35	30	40	111	64		382	377	368	358	346	329	311	290	267	240	211	180	148

\*更高壓力,最大段數至54段的產品可以按需求提供.

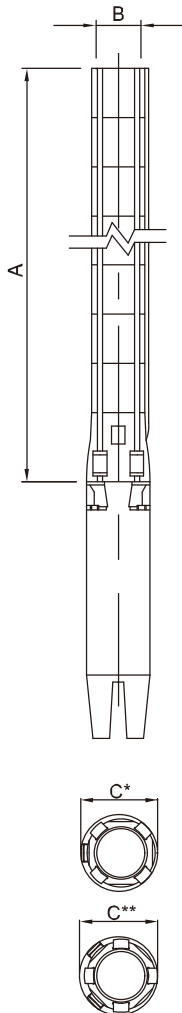

尺寸和重量

Pump Type	Dimensions(mm)				Net Weight(Kg)
	A	B	C*	C**	Pump
SP150-2	462	NPT/ RP 3"	131		8.4
SP150-3	558		131		10,1
SP150-4	654		131		11,8
SP150-6	846		131		15,2
SP150-8	1038		142	142	18,6
SP150-11	1326		142	142	23,6
SP150-13	1518		142	142	27,0
SP150-15	1710		142	142	30,4
SP150-17	1902		142	142	33,8
SP150-19	2094		142	142	37,2
SP150-21	2286		142	142	40,6
SP150-24	2574		142	142	45,6
SP150-26	2766		142	142	49,0
SP150-29	3054		142	142	54,1
SP150-32	3342		142	142	59,2
SP150-35	3630		142	142	64,3

C\*: 泵的最大直徑包含1個纜纜護套  
C\*\*: 泵的最大直徑包含2個纜纜護套



# Stairs SP Series

## 性能曲綫 SP230

SP 6"

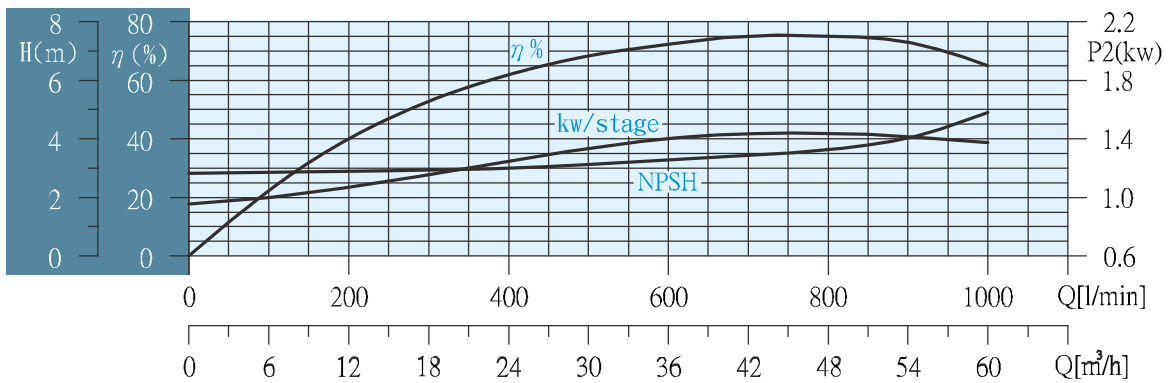
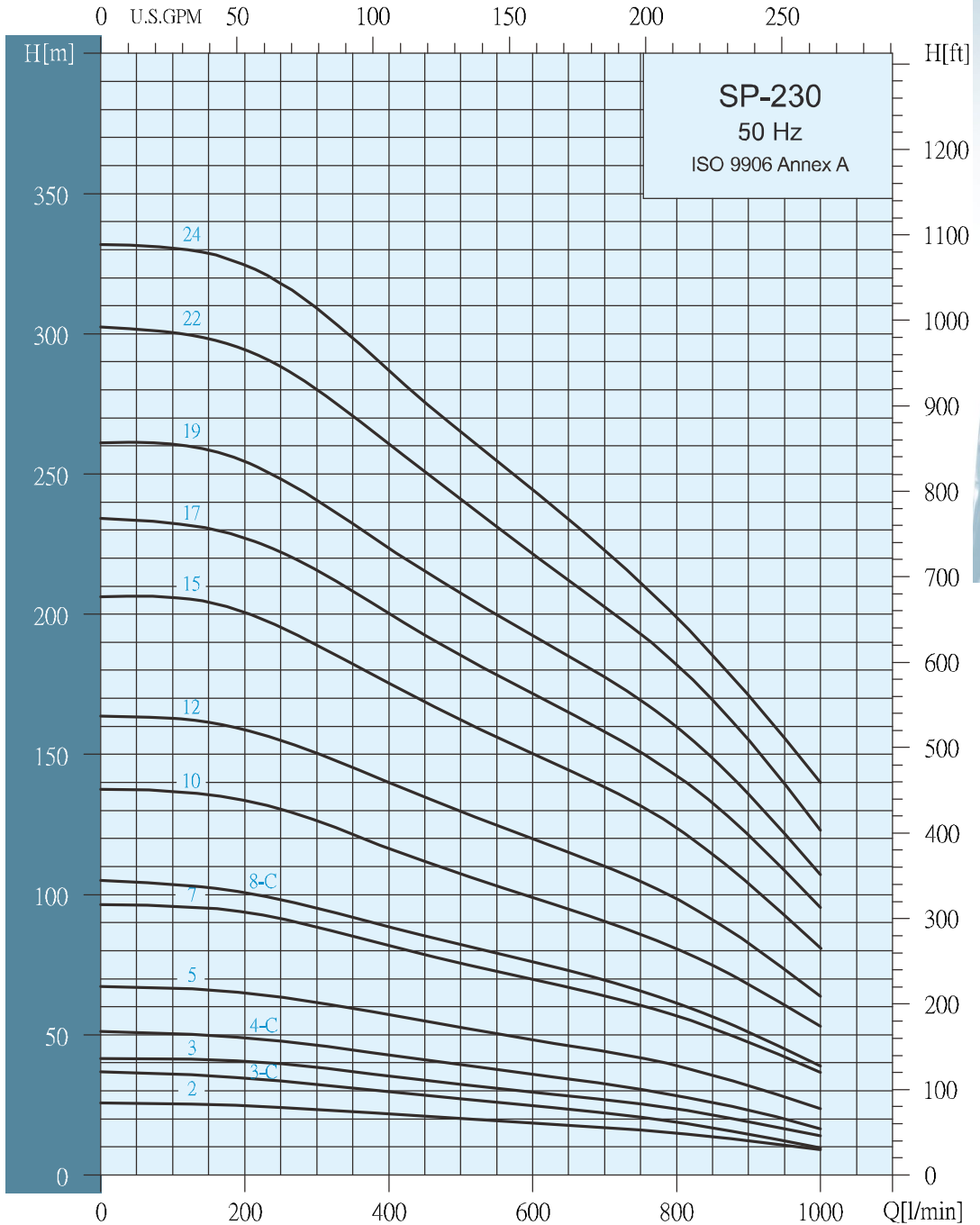

### 選型數據

Pump Type	Motor		Max.current		Q capacity 2900 rpm												
	P2		Amp		m <sup>3</sup> /h l/min	12	15	18	21	24	27	30	36	42	48	54	60
	KW	HP	220V	380V		200	250	300	350	400	450	500	600	700	800	900	1000
SP230-2	3	4	13.3	7.7	HEAD IN METERS	24	23.5	23	22.5	22	21	20	18	17	15	12	9
SP230-3C	3.7	5	15.4	8.9		35	34	32	31	29	28	27	24	22	19	14	10
SP230-3	5.5	7.5	22.2	12.8		40	39	38	37	35	34	33	29	27	23	18	14
SP230-4C	5.5	7.5	22.2	12.8		49	47	46	45	43	41	39	36	32	28	23	17
SP230-5	7.5	10	28.5	16.5		65	63	61	59	57	55	53	48	44	39	32	24
SP230-7	11	15	41.8	24.2		94	92	88	85	82	79	76	70	64	57	47	37
SP230-8C	11	15	41.8	24.2		100	98	95	92	88	85	82	76	69	61	51	39
SP230-10	15	20	55	32		133	130	127	122	117	112	107	98	90	80	67	53
SP230-12	18.5	25	69	40		158	155	150	145	140	135	130	120	110	98	83	64
SP230-15	22	30	81	47		200	195	189	183	176	169	163	150	138	124	103	81
SP230-17	26	35	96	56		227	222	215	208	200	193	186	172	158	143	121	96
SP230-19	30	40	111	64		254	248	241	233	224	216	208	193	178	160	136	107
SP230-22	37	50	138	80		294	288	280	270	260	251	241	222	203	183	155	123
SP230 24	37	50	138	80		325	317	309	298	287	276	265	244	223	199	171	140

\*更高壓力,最大段數至37段的產品可以按需求提供。

### 尺寸和重量

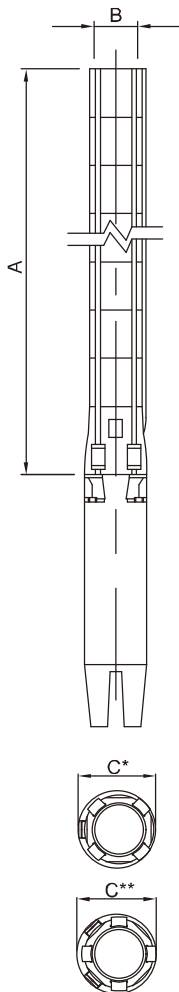

Pump Type	Dimensions(mm)				Net Weight(Kg)
	A	B	C*	C**	Pump
SP230-2	496	NPT/RP 3" or 4"	146		9.2
SP230-3-C	609		146		11.5
SP230-3	609		146		11.5
SP230-4-C	722		146		13.8
SP230-5	835		149	152	16.0
SP230-7	1061		149	152	20.6
SP230-8-C	1174		149	152	22.9
SP230-10	1400		149	152	27.4
SP230-12	1626		149	152	32.0
SP230-15	1965		149	152	38.8
SP230-17	2191		149	152	43.4
SP230-19	2417		149	152	47.9
SP230-22	2756		149	152	54.8
SP230-24	2982		149	152	59.3

C\*: 泵的最大直徑包含1個纜護套  
C\*\*: 泵的最大直徑包含2個纜護套



# Stairs SP Series

## 性能曲綫 SP300

SP 6"

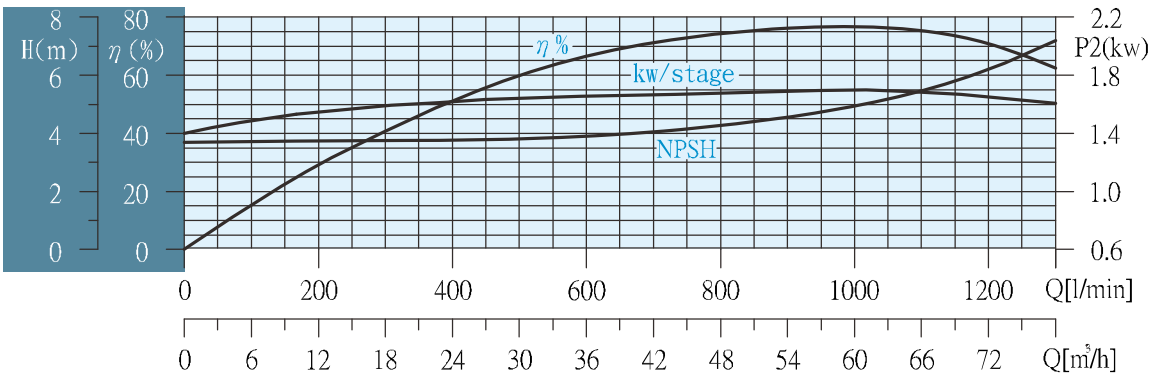
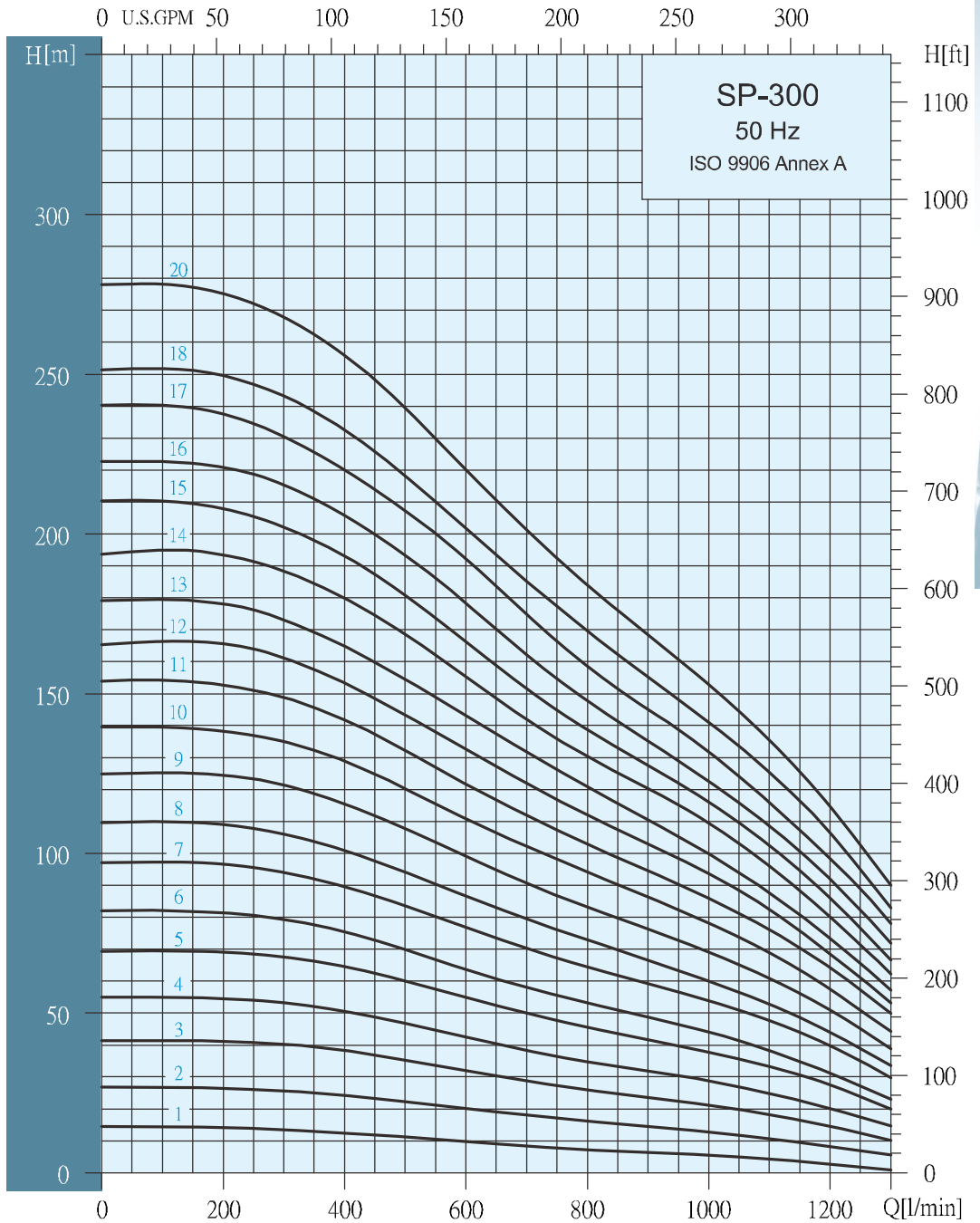

### 選型數據

Pump Type	Motor		Max.current		Q capacity 2900 rpm													
	P2		Amp		m³/h l/min	18	21	24	27	30	36	42	48	54	60	66	72	78
	KW	HP	220V	380V		300	350	400	450	500	600	700	800	900	1000	1100	1200	1300
SP300-1	2.2	3	9.5	5.5	HEAD IN METERS	13	12.5	12	11.5	11	10	8	7	6	5	4	2	1
SP300-2	4	5.5	15.4	8.9		26	25	24	23	22	20	18	16	14	13	11	8	5
SP300-3	5.5	7.5	22.2	12.8		40	39	38	37	36	32	28	26	24	21	18	14	10
SP300-4	7.5	10	28.5	16.5		53	52	51	48	47	43	38	35	32	28	25	20	14
SP300-5	9.3	12.5	36	20.9		67	66	64	62	60	55	50	46	42	38	33	27	19
SP300-6	11	15	41.8	24.2		79	78	76	73	70	64	58	53	48	44	38	32	23
SP300-7	13	17.5	50	29		94	92	89	86	84	77	70	64	59	54	47	40	29
SP300-8	15	20	55	32		106	104	101	97	94	87	80	73	67	60	53	44	33
SP300-9	18.5	25	69	40		122	118	116	112	108	99	91	83	76	69	61	51	38
SP300-10	18.5	25	69	40		135	132	128	125	120	111	102	95	87	78	68	57	45
SP300-11	22	30	81	47		148	146	142	137	132	122	112	103	95	86	76	64	49
SP300-12	22	30	81	47		162	157	153	148	143	133	122	112	103	94	83	68	53
SP300-13	26	35	96	56		173	169	165	160	155	143	132	121	110	100	87	73	57
SP300-14	26	35	96	56		188	184	180	175	168	156	142	130	120	109	96	80	63
SP300-15	26	35	96	56		203	197	193	187	180	166	152	138	127	116	103	86	67
SP300-16	30	40	111	64		216	211	206	200	193	178	162	148	135	123	108	92	72
SP300-17	37	50	138	80		230	226	220	214	207	192	175	158	145	132	116	97	78
SP300-18	37	50	138	80		243	238	233	226	218	202	185	170	155	141	126	107	83
SP300-20	37	50	138	80		267	263	256	248	239	220	201	184	168	153	136	115	90

\*更高壓力,最大段數至30段的產品可以按需求提供.

### 尺寸和重量

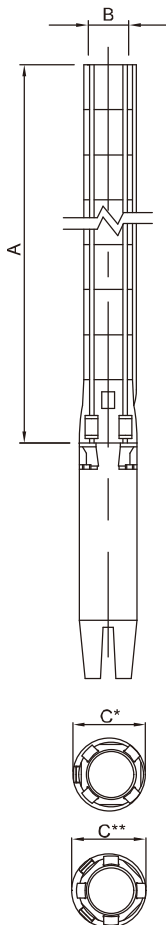

Pump Type	Dimensions(mm)				Net Weight(Kg)
	A	B	C*	C**	Pump
SP300-1	383	NPT/RP 3" or 4"	146		6.9
SP300-2	496		146		9.2
SP300-3	609		146		11.5
SP300-4	722		149	152	13.7
SP300-5	835		149	152	16.0
SP300-6	948		149	152	18.3
SP300-7	1061		149	152	20.6
SP300-8	1174		149	152	22.9
SP300-9	1287		149	152	25.1
SP300-10	1400		149	152	27.4
SP300-11	1513		149	152	29.7
SP300-12	1626		149	152	32.0
SP300-13	1739		149	152	34.3
SP300-14	1852		149	152	36.5
SP300-15	1965		149	152	38.8
SP300-16	2078		149	152	41.1
SP300-17	2191		149	152	43.4
SP300-18	2304		149	152	45.7
SP300-20	2530		149	152	50.2

C\*: 泵的最大直徑包含1個纜護套  
C\*\*: 泵的最大直徑包含2個纜護套



# Stairs SP Series

## 性能曲綫 SP400 SP 8"

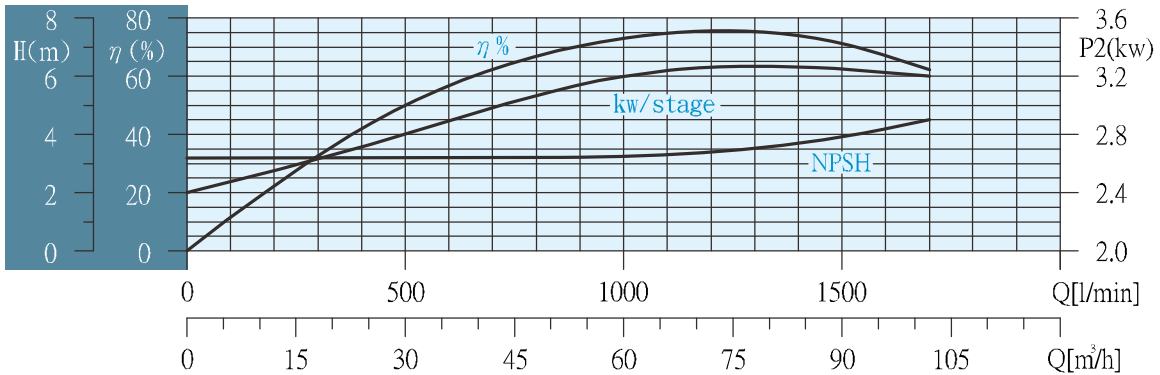
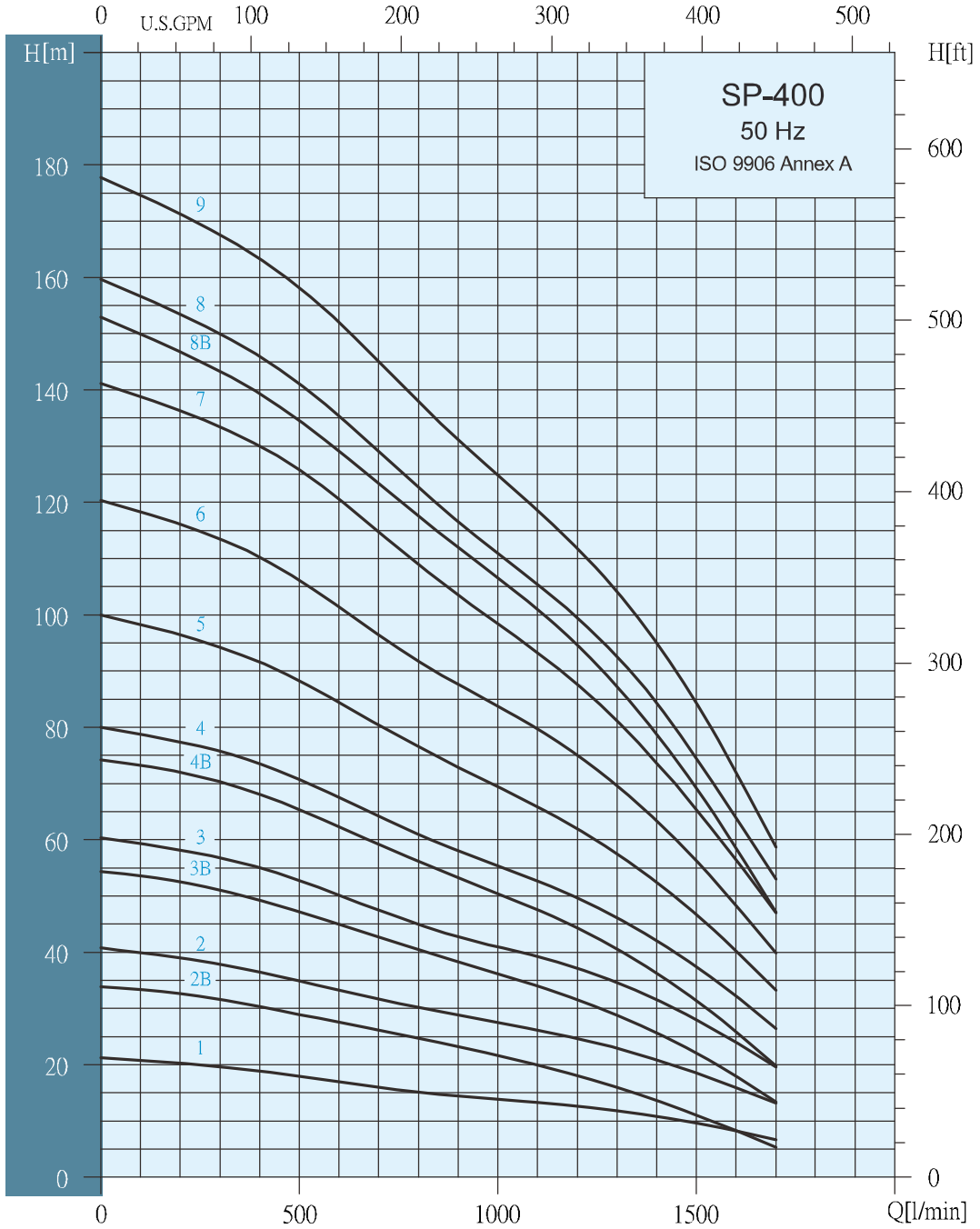





STAIRS PUMPS

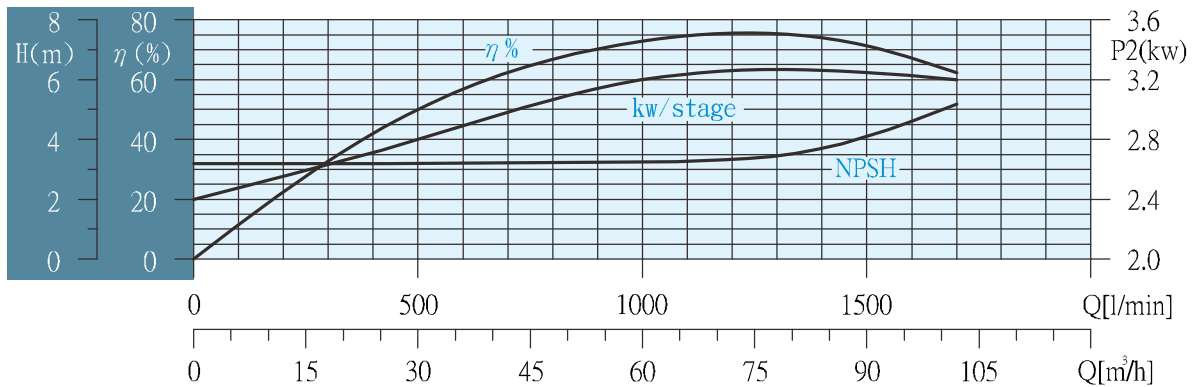
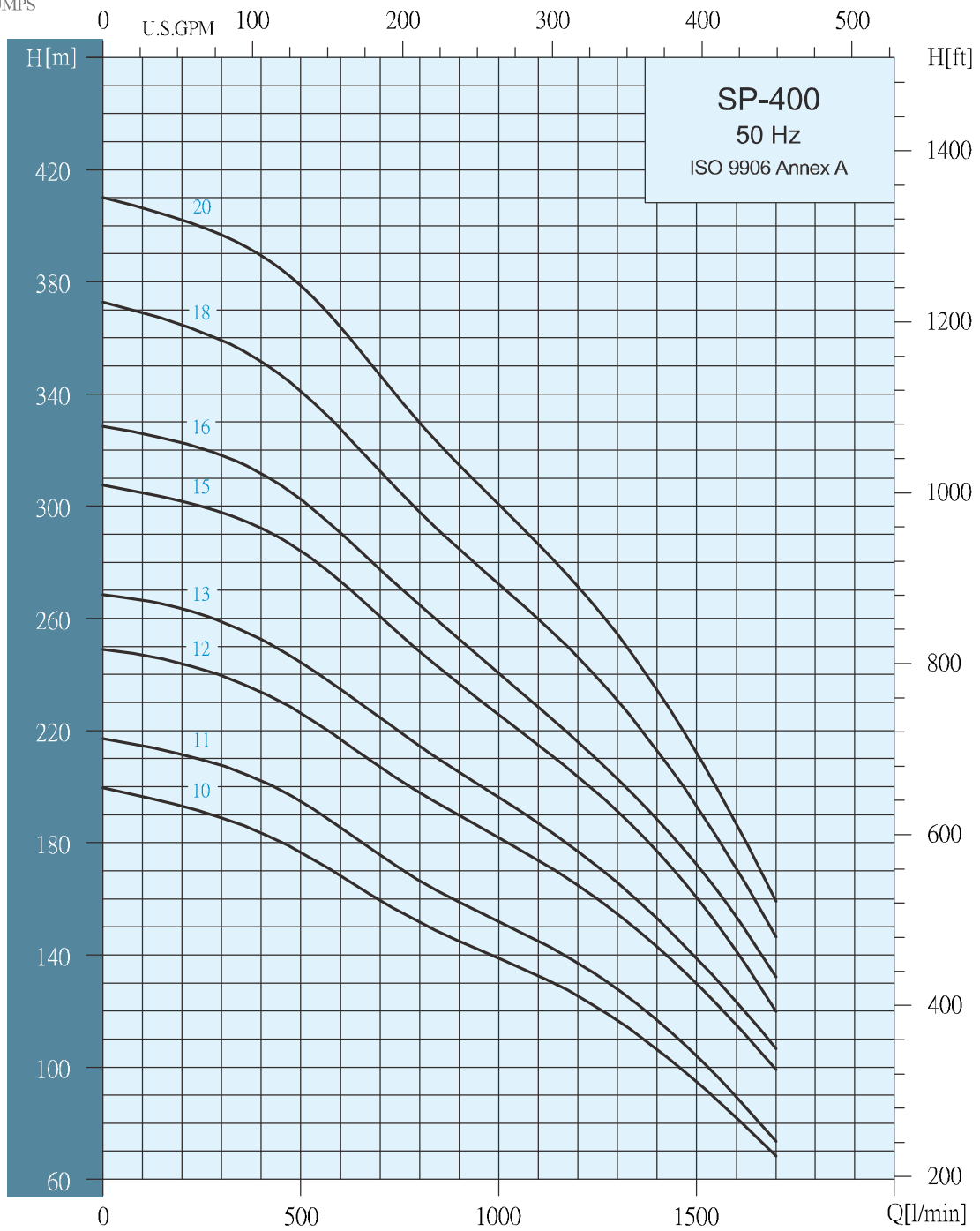



STAIRS PUMPS

# Stairs SP Series

## 性能曲綫 SP400

SP 8"

### 選型數據

Pump Type	Motor		Max.current		Q capacity 2900 rpm												
	P2		Amp		m³/h l/min	12	18	24	30	36	42	48	54	66	78	90	102
	KW	HP	220V	380V		200	300	400	500	600	700	800	900	1100	1300	1500	1700
SP 400-1	5.5	7.5	21.9	12.7	HEAD IN METERS	20	19.5	19	18	17	16	15	14	13	12	9	7
SP 400-2-B	5.5	7.5	21.9	12.7		33	32	30	28	27	26	25	23	20	16	11	6
SP 400-2	7.5	10	28.5	16.5		38	37	36	35	33	32	30	28	26	23	18	13
SP 400-3-B	9.3	12.5	36	20.9		53	51	49	47	45	43	40	38	34	28	22	13
SP 400-3	11	15	41.8	24.2		58	57	55	53	50	47	45	43	39	35	28	20
SP 400-4-B	13	17.5	50	29		72	70	68	65	62	59	56	53	47	40	31	20
SP 400-4	15	20	55	32		77	76	74	71	67	64	61	58	53	46	37	27
SP 400-5	18.5	25	69	40		96	94	92	88	84	80	76	73	66	57	46	33
SP 400-6	22	30	81	47		116	113	110	106	101	96	92	88	80	70	56	40
SP 400-7	26	35	96	56		136	133	130	126	120	115	109	104	93	81	65	47
SP 400-8-B	26	35	96	56		147	143	139	134	129	123	117	112	101	87	69	47
SP 400-8	30	40	111	64		153	150	146	141	135	129	123	117	105	93	75	53
SP 400-9	30	40	111	64		171	167	163	158	152	145	138	131	118	104	84	58
SP 400-10	37	50	138	80		193	188	183	177	168	160	152	145	132	117	94	68
SP 400-11	37	50	138	80		211	207	202	195	186	176	167	159	145	128	104	74
SP 400-12	45	60	154	89		244	240	234	227	217	207	198	190	173	154	130	99
SP 400-13	55	75	192	111		263	259	252	244	235	224	214	205	187	166	139	107
SP 400-15	55	75	192	111		302	298	292	284	273	260	248	237	215	191	160	120
SP 400-16	63	85	240	139		322	318	312	302	290	278	265	252	228	202	172	132
SP 400-18	63	85	240	139		365	359	352	341	328	312	298	285	260	230	193	147
SP 400-20	75	100	256	148	402	397	389	379	364	347	330	315	287	254	212	159	

\*更高壓力，最大段數至22段的產品可以按需求提供

### 尺寸和重量

Pump Type	Dimensions(mm)						Net Weight(Kg)
	B 5" Connection (RP,NPT)			B 5" Flange			
	A	C*	C**	A	C*	C**	Pump
SP 400-1	618	178	186	618	200	200	25.1
SP 400-2-B	746	178	186	746	200	200	28.7
SP 400-2	746	178	186	746	200	200	28.7
SP 400-3-B	874	178	186	874	200	200	32.3
SP 400-3	874	178	186	874	200	200	32.3
SP 400-4-B	1003	178	186	1003	200	200	35.9
SP 400-4	1003	178	186	1003	200	200	35.9
SP 400-5	1131	178	186	1131	200	200	35.9
SP 400-6	1259	178	186	1259	200	200	43.0
SP 400-7	1387	178	186	1387	200	200	46.6
SP 400-8-B	1515	178	186	1515	200	200	50.2
SP 400-8	1515	178	186	1515	200	200	50.2
SP 400-9	1644	178	186	1644	200	200	53.8
SP 400-10	1772	178	186	1772	200	200	57.4
SP 400-11	1900	178	186	1900	200	200	61.0
SP 400-12	2039	200	204	2039	209	209	66.0
SP 400-13	2168	200	204	2168	209	209	69.6
SP 400-15	2424	200	204				76.8
SP 400-16	2552	200	204				80.4
SP 400-18	2809	200	204				87.6
SP 400-20	3065	200	204				94.8

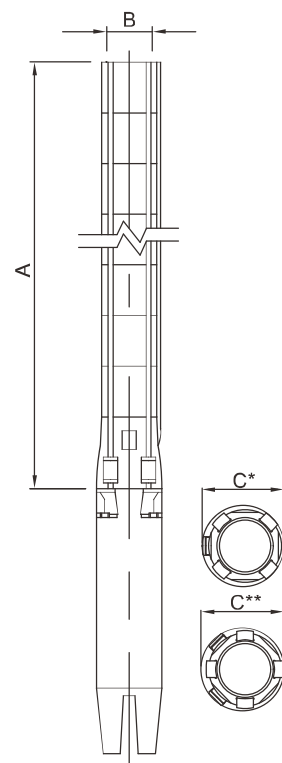

C\*: 泵的最大直徑包含1個綫纜護套  
 C\*\*: 泵的最大直徑包含2個綫纜護套



STAIRS PUMPS

# Stairs SP Series

性能曲綫 **SP500**

SP 8"

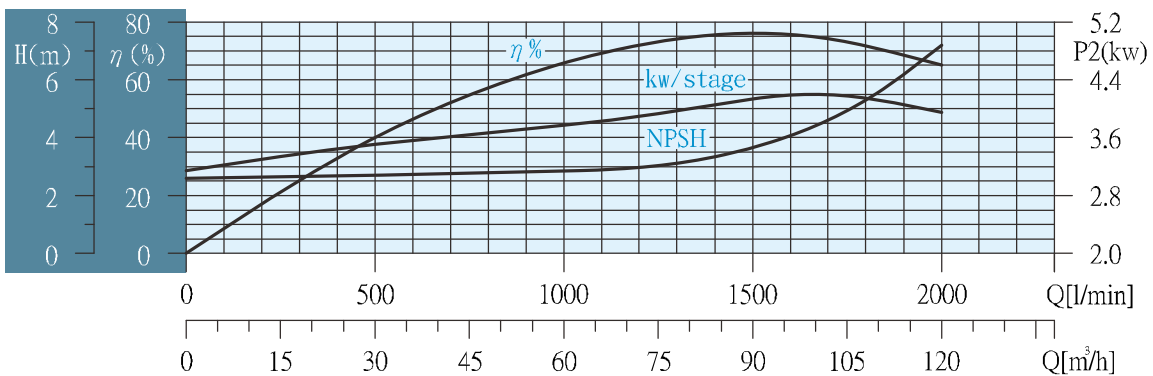
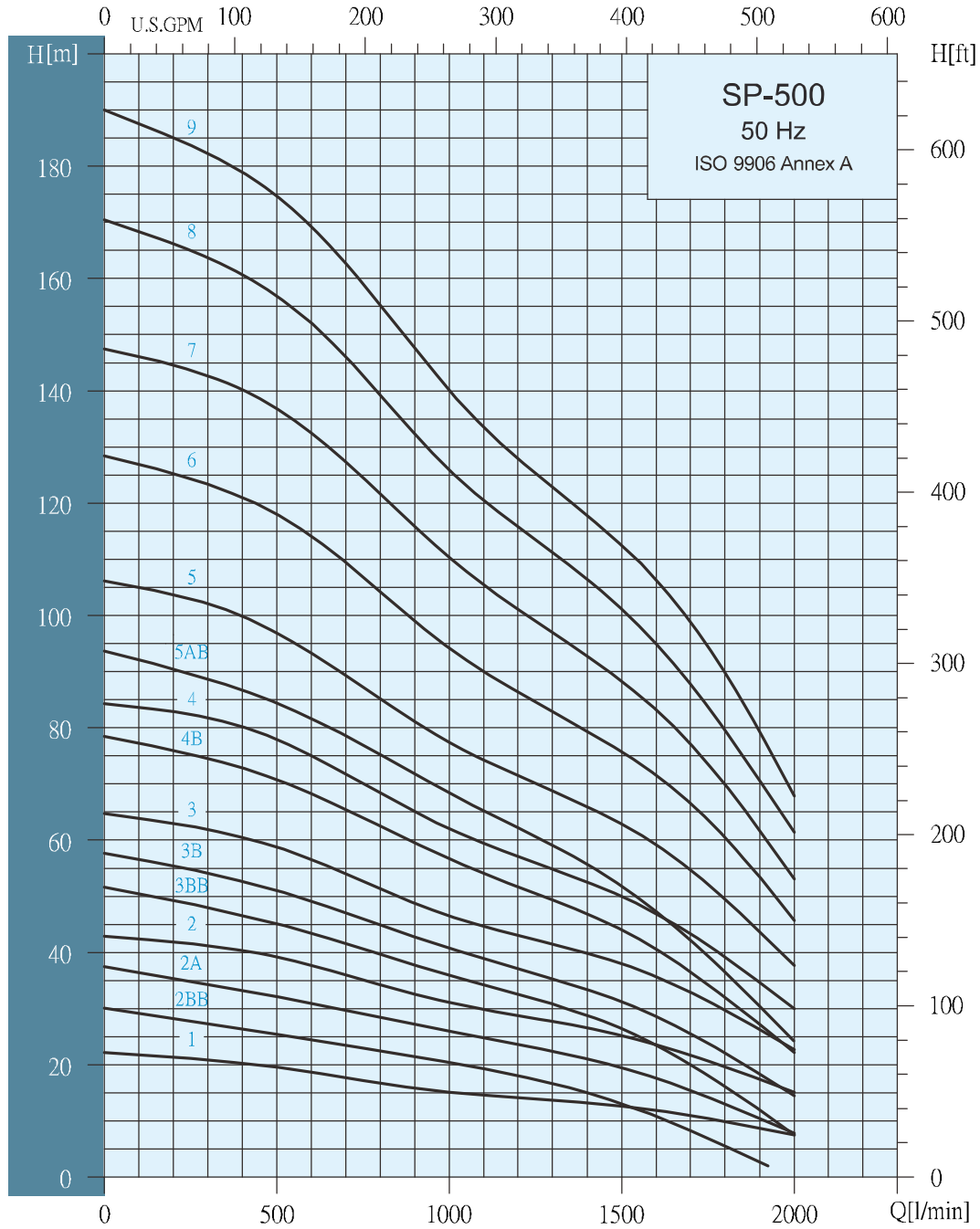



STAIRS PUMPS

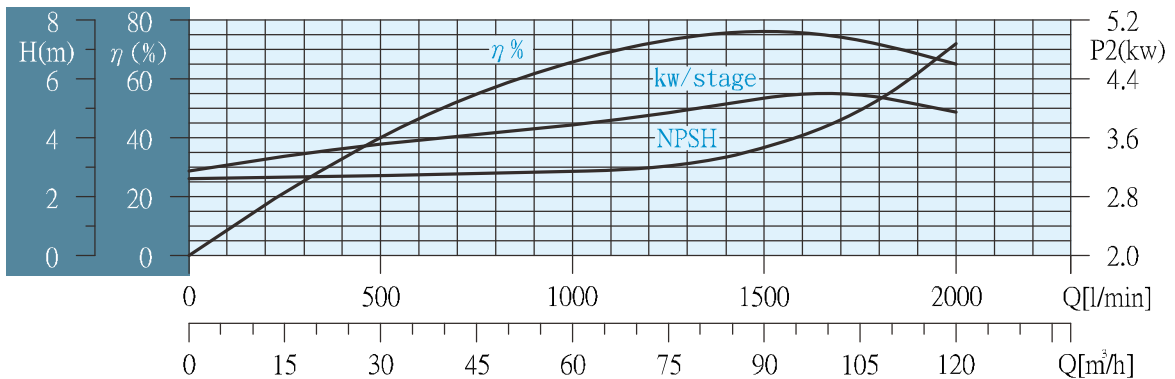
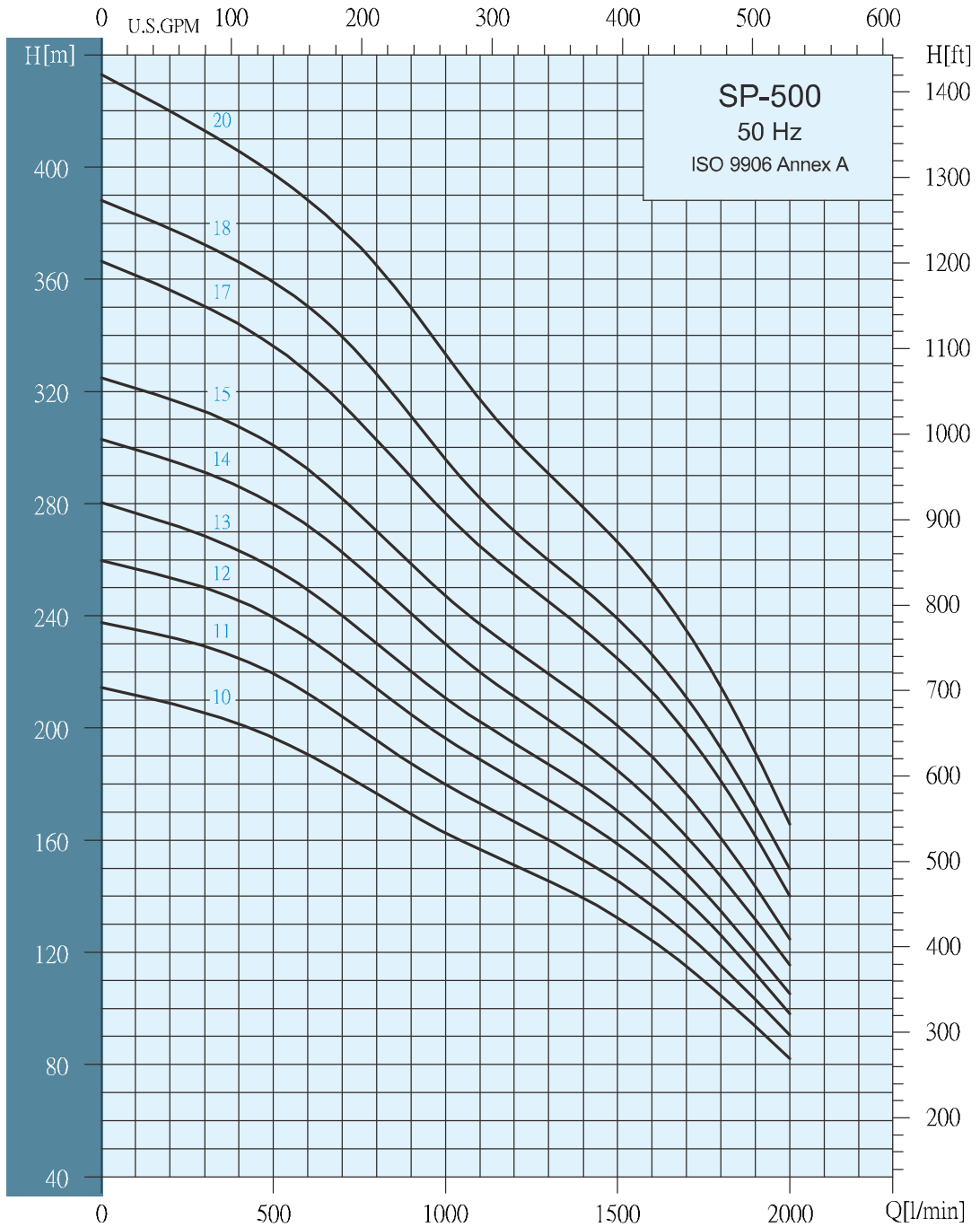

### 選型數據

Pump Type	Motor		Max.current		m³/h l/min	Q capacity 2900 rpm											
	P2		Amp			18	24	30	36	42	48	60	72	84	96	108	120
	KW	HP	220V	380V		300	400	500	600	700	800	1000	1200	1400	1600	1800	2000
SP 500-1	5.5	7.5	21.9	12.7	HEAD IN METERS	21	20	19	18	17.5	17	15	14	13	12	10	8
SP 500-2-BB	5.5	7.5	21.9	12.7		27	26	25	24	23	22	20	18	15	11	5	0
SP 500-2-A	7.5	10	28.5	16.5		34	33	32	31	30	28	26	24	21	17	13	8
SP 500-2	9.3	12.5	36	20.9		41	40	39	37	36	34	31	29	26	23	20	15
SP 500-3-BB	9.3	12.5	36	20.9		48	46	45	43	41	40	36	33	28	23	16	8
SP 500-3-B	11	15	41.8	24.2		54	53	51	49	47	45	41	37	33	28	22	15
SP 500-3	13	17.5	50	29		62	60	59	57	54	51	47	43	40	35	30	23
SP 500-4-B	15	20	55	32		74	73	71	68	65	62	56	52	47	40	32	22
SP 500-4	18.5	25	69	40		82	80	78	75	72	68	62	57	53	47	39	30
SP 500-5-AB	18.5	25	69	40		89	87	84	82	78	75	68	62	55	47	36	25
SP 500-5	22	30	81	47		102	100	97	94	90	85	77	72	66	59	50	38
SP 500-6	26	35	96	56		123	121	118	114	110	104	94	86	79	72	60	46
SP 500-7	30	40	111	64		143	140	137	132	127	121	110	101	93	83	70	53
SP 500-8	37	50	138	80		164	160	157	152	146	139	126	116	106	95	80	62
SP 500-9	37	50	138	80		182	179	175	169	163	155	140	128	118	106	90	68
SP 500-10	45	60	154	89		206	201	197	190	183	177	162	150	140	124	105	82
SP 500-11	55	75	192	111		230	225	220	212	204	196	180	167	152	137	116	90
SP 500-12	55	75	192	111		250	245	240	231	222	214	197	181	167	150	126	99
SP 500-13	55	75	192	111		268	263	258	250	240	230	210	195	180	160	135	106
SP 500-14	63	85	240	139		291	286	280	271	261	251	230	210	194	174	147	116
SP 500-15	75	100	256	148	312	308	300	292	281	270	248	228	210	190	160	126	
SP 500-17	75	100	256	148	350	344	336	327	316	302	277	255	235	212	180	140	
SP 500-18	93	125	335	194	372	366	360	350	340	326	296	270	250	227	192	150	
SP 500-20	93	125	335	194	412	406	397	388	378	365	333	302	279	251	214	166	

### 尺寸和重量

Pump Type	Dimensions(mm)						Net Weight(Kg)
	B 5" Connection (RP,NPT)			B 5" Flange			
	A	C*	C**	A	C*	C**	Pump
SP 500-1	618	178	186	618	200	200	25.1
SP 500-2-BB	746	178	186	746	200	200	28.7
SP 500-2-A	746	178	186	746	200	200	28.7
SP 500-2	746	178	186	746	200	200	28.7
SP 500-3-BB	874	178	186	874	200	200	32.3
SP 500-3-B	874	178	186	874	200	200	32.3
SP 500-3	874	178	186	874	200	200	32.3
SP 500-4-B	1003	178	186	1003	200	200	35.9
SP 500-4	1003	178	186	1003	200	200	35.9
SP 500-5-AB	1131	178	186	1131	200	200	39.5
SP 500-5	1131	178	186	1131	200	200	39.5
SP 500-6	1259	178	186	1259	200	200	43.0
SP 500-7	1387	178	186	1387	200	200	46.6
SP 500-8	1515	178	186	1515	200	200	50.2
SP 500-9	1644	178	186	1644	200	200	53.8
SP 500-10	1783	196	204	1783	205	205	58.8
SP 500-11	1911	196	204	1911	205	205	62.4
SP 500-12	2039	196	204	2039	205	205	66.0
SP 500-13	2168	196	204	2168	205	205	69.6
SP 500-14	2296	196	204	2296	205	205	73.2
SP 500-15	2424	196	204				76.7
SP 500-17	2680	196	204				84.0
SP 500-18	2809	196	204				87.6
SP 500-20	3065	196	204				94.8

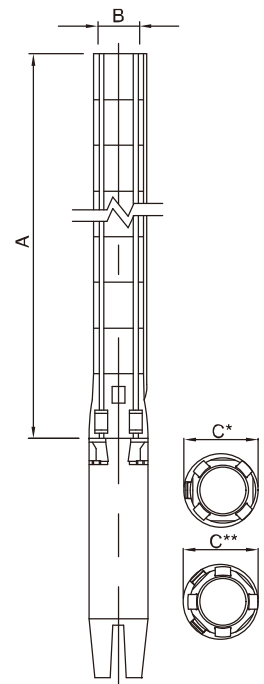

C\*: 泵的最大直徑包含1個纜纜護套  
 C\*\*: 泵的最大直徑包含2個纜纜護套



# Stairs SP Series

## 性能曲綫 SP650

SP 10"

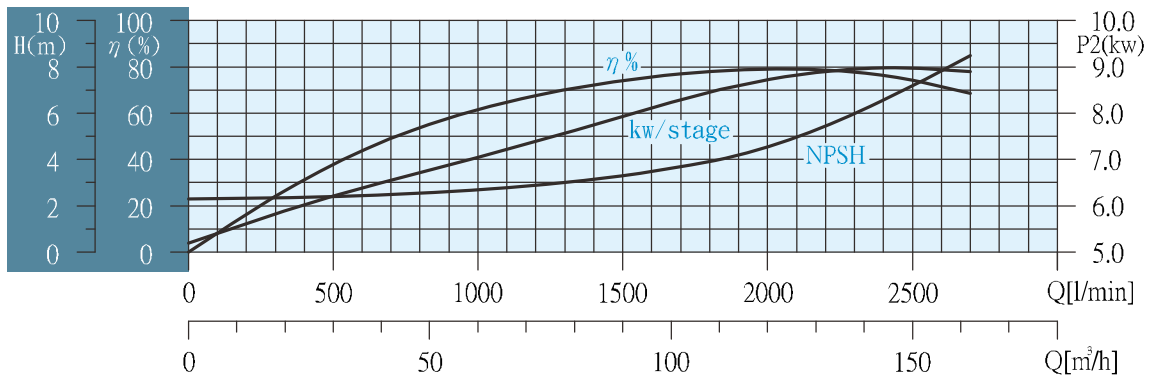
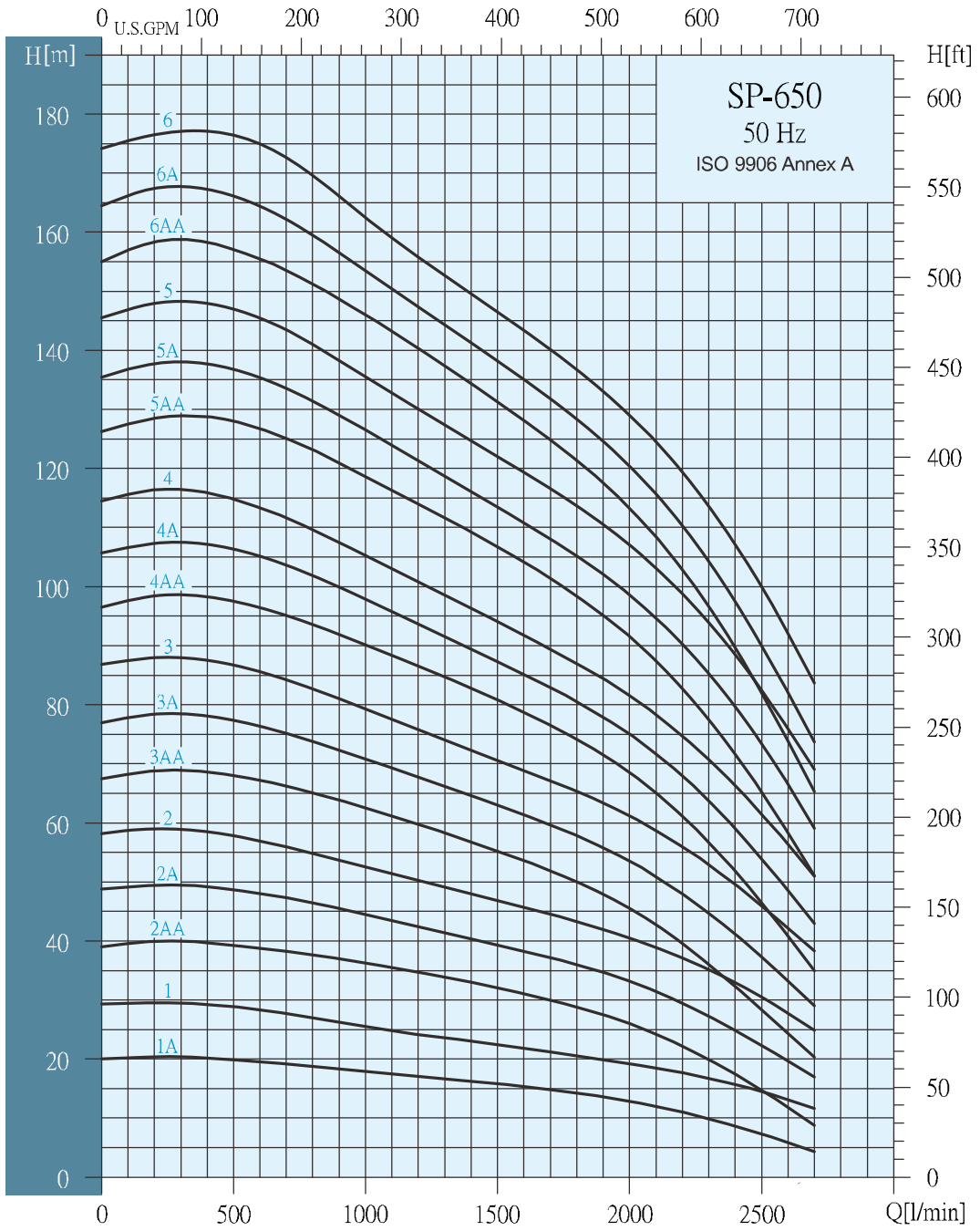





STAIRS PUMPS

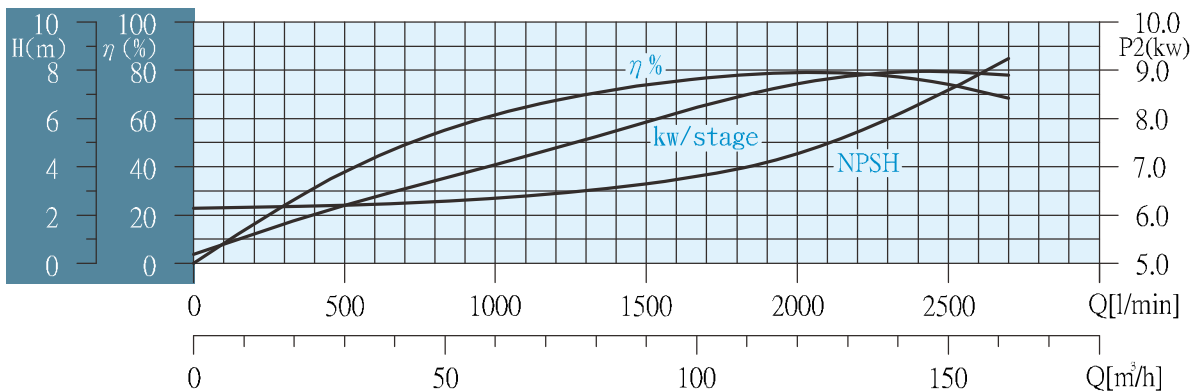
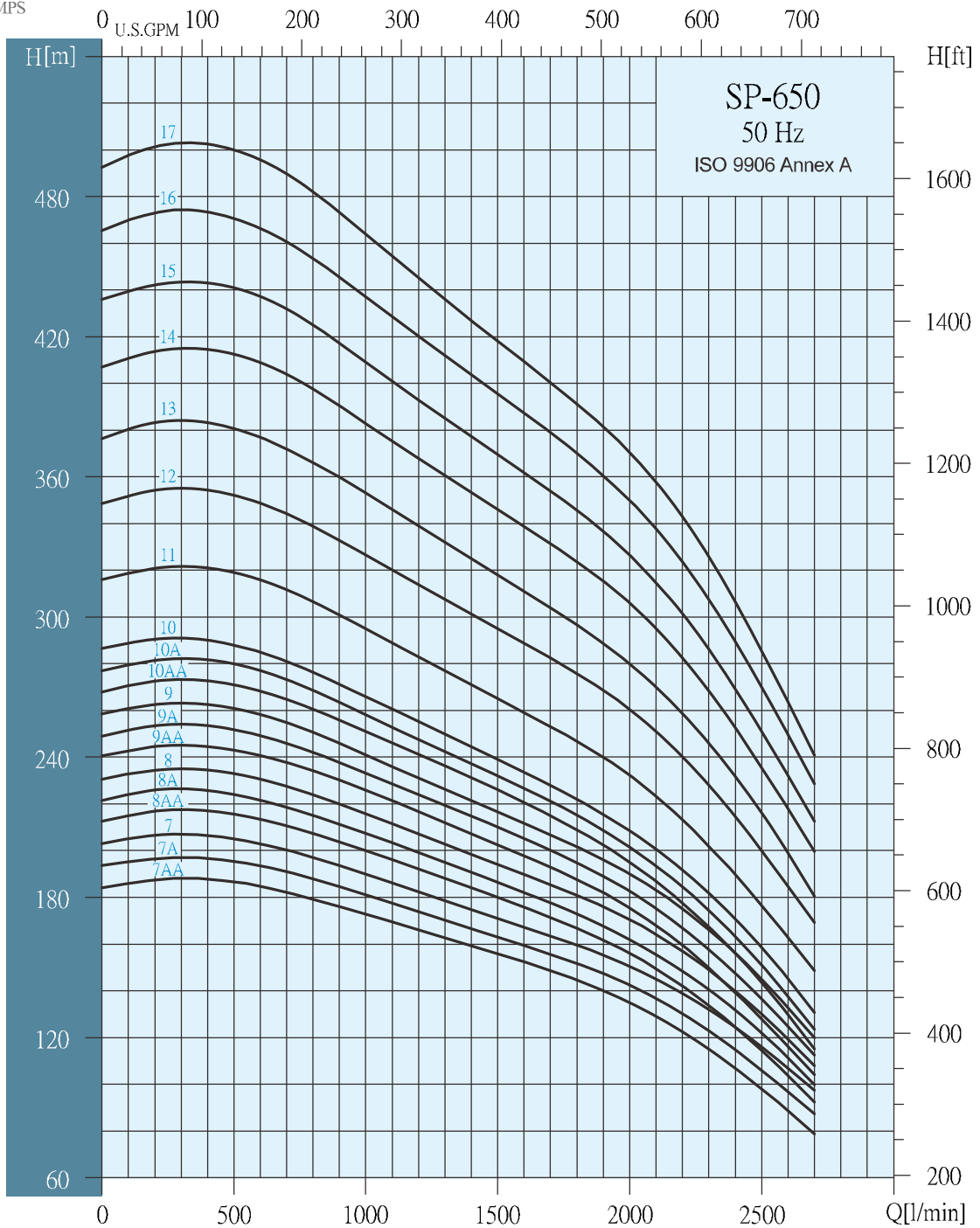





STAIRS PUMPS

# Stairs SP Series

## 性能曲綫 SP650

SP10"

### 選型數據

Pump Type	Motor		Max.current		m³/h l/min	Q capacity 2900 rpm											
	P2		Amp			30	42	54	66	78	90	102	114	126	138	150	162
	KW	HP	220V	380V		500	700	900	1100	1300	1500	1700	1900	2100	2300	2500	2700
SP 650-1-A	7.5	10	28.5	16.5	20	19	18	18	17	16	15	14	12	10	7	4	
SP 650-1	11	15	41.8	24.2	29	28	26	25	24	22	22	20	18	17	15	12	
SP 650-2-AA	13	17.5	50	29	39	38	37	36	34	32	30	28	24	20	15	9	
SP 650-2-A	18.5	25	69	40	49	48	46	44	41	39	38	35	32	28	22	17	
SP 650-2	22	30	81	47	58	56	54	52	49	47	44	42	39	35	31	25	
SP 650-3-AA	22	30	81	47	68	66	64	61	58	55	52	48	43	36	29	20	
SP 650-3-A	26	35	96	56	77	75	73	69	66	63	60	56	51	45	37	29	
SP 650-3	30	40	111	64	87	89	81	78	74	71	68	63	58	53	46	39	
SP 650-4-AA	37	50	138	80	98	95	92	88	85	81	77	72	65	67	47	35	
SP 650-4-A	37	50	138	80	106	104	100	96	92	87	83	78	72	64	54	43	
SP 650-4	37	50	138	80	115	112	108	103	98	94	89	84	78	71	62	51	
SP 650-5-AA	45	60	154	89	128	125	121	116	112	107	101	95	87	78	65	51	
SP 650-5-A	45	60	154	89	137	133	129	124	119	114	108	102	95	85	73	59	
SP 650-5	55	75	192	111	147	144	138	133	128	122	117	111	103	94	83	69	
SP 650-6-AA	55	75	192	111	157	154	149	143	138	131	125	118	108	97	82	65	
SP 650-6-A	55	75	192	111	166	162	156	151	144	138	132	125	116	104	90	74	
SP 650-6	63	85	240	139	176	173	166	159	153	147	140	133	124	114	100	84	
SP 650-7-AA	63	85	240	139	187	183	176	170	163	156	148	140	129	115	98	79	
SP 650-7-A	63	85	240	139	196	191	185	178	170	163	155	148	137	123	106	83	
SP 650-7	75	100	256	148	205	200	194	186	178	171	164	155	145	132	116	98	
SP 650-8-AA	75	100	256	148	216	211	204	196	188	180	172	162	149	134	115	93	
SP 650-8-A	75	100	256	148	224	218	212	204	195	187	178	168	156	141	122	100	
SP 650-8	75	100	256	148	233	227	220	212	203	194	186	176	165	149	130	108	
SP 650-9-AA	93	125	335	194	243	238	230	221	212	203	193	182	168	150	128	104	
SP 650-9-A	93	125	335	194	252	245	237	228	219	210	200	189	175	158	137	113	
SP 650-9	93	125	335	194	261	255	246	236	226	217	207	196	183	166	145	120	
SP 650-10-AA	93	125	335	194	271	265	256	246	236	226	215	203	186	167	144	115	
SP 650-10-A	93	125	335	194	280	273	264	253	243	232	221	209	193	175	151	123	
SP 650-10	93	125	335	194	288	281	271	261	250	239	227	215	201	182	159	131	
SP 650-11	110	150	390	226	319	312	301	289	277	265	254	240	223	202	177	149	
SP 650-12	132	175			352	345	333	320	308	295	283	269	251	228	200	169	
SP 650-13	132	175			381	372	360	346	332	318	304	289	270	246	216	180	
SP 650-14	147	200			413	404	390	375	361	346	332	316	295	269	236	200	
SP 650-15	147	200			441	431	417	401	385	370	354	336	315	286	251	213	
SP 650-16	170	230			471	460	445	428	412	396	379	361	338	308	270	229	
SP 650-17	170	230			500	490	473	455	436	418	406	382	358	325	286	241	

HEAD IN METERS

### 尺寸和重量

Pump Type	motor Dia.	Dimensions(mm)						Net Weight(Kg)
		B6" Connection (RP,NPT)			B 6 " Flange			
		A	C*	C**	A	C*	C**	
SP 650-1-A	6"	652	211	218	652	222	226	29.2
SP 650-1	6"	652	211	218	652	222	226	29.3
SP 650-2-AA	6"	807	211	218	807	222	226	35.6
SP 650-2-A	6"	807	211	218	807	222	226	35.7
SP 650-2	6"	807	211	218	807	222	226	35.8
SP 650-3-AA	6"	963	211	218	963	222	226	42.1
SP 650-3-A	6"	963	211	218	963	222	226	42.2
SP 650-3	6"	963	211	218	963	222	226	42.3
SP 650-3	8"	963	213	218	963	223	226	47.1
SP 650-4-AA	6"	1118	211	218	1118	222	226	48.6
SP 650-4-AA	8"	1118	213	218	1118	223	226	51.9
SP 650-4-A	6"	1118	211	218	1118	222	226	48.7
SP 650-4-A	8"	1118	213	218	1118	223	226	52.0
SP 650-4	6"	1118	211	218	1118	222	226	48.8
SP 650-4	8"	1118	213	218	1118	223	226	52.1
SP 650-5-AA	6"	1274	211	218	1274	222	226	55.1
SP 650-5-AA	8"	1274	213	218	1274	223	226	56.9
SP 650-5-A	6"	1274	211	218	1274	222	226	55.2
SP 650-5-A	8"	1274	213	218	1274	223	226	57.0
SP 650-5	8"	1274	213	218	1274	223	226	57.1
SP 650-6-AA	8"	1429	213	218	1429	223	226	61.9
SP 650-6-A	8"	1429	213	218	1429	223	226	62.0
SP 650-6	8"	1429	218	227	1429	229	232	62.1
SP 650-7-AA	8"	1585	218	227	1585	229	232	66.9
SP 650-7-A	8"	1585	218	227	1585	229	232	67.0
SP 650-7	8"	1585	218	227	1585	229	232	67.1
SP 650-8-AA	8"	1740	218	227				71.9
SP 650-8-A	8"	1740	218	227				72.0
SP 650-8	8"	1740	218	227				72.1
SP 650-9-AA	8"	1896	218	227				76.9
SP 650-9-A	8"	1896	218	227				77.0
SP 650-9	8"	1896	218	227				77.1
SP 650-10-AA	8"	2051	218	227				81.9
SP 650-10-A	8"	2051	218	227				82.0
SP 650-10	8"	2051	218	227				82.1
SP 650-11	8"	2207	218	227				87.1
SP 650-12	10"	2492	227	247				109.5
SP 650-13	10"	2648	227	247				116.0
SP 650-14	10"	2803	227	247				122.5
SP 650-15	10"	2959	227	247				129.0
SP 650-16	10"	3114	227	247				135.5
SP 650-17	10"	3270	227	247				142.0

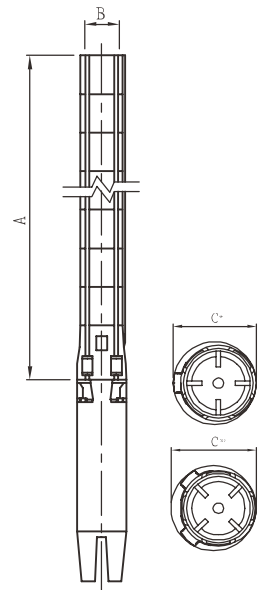

C\*: 泵的最大直徑包含1個綫纜護套  
C\*\*: 泵的最大直徑包含2個綫纜護套



# Stairs SP Series

性能曲綫 **SP800**

SP10"

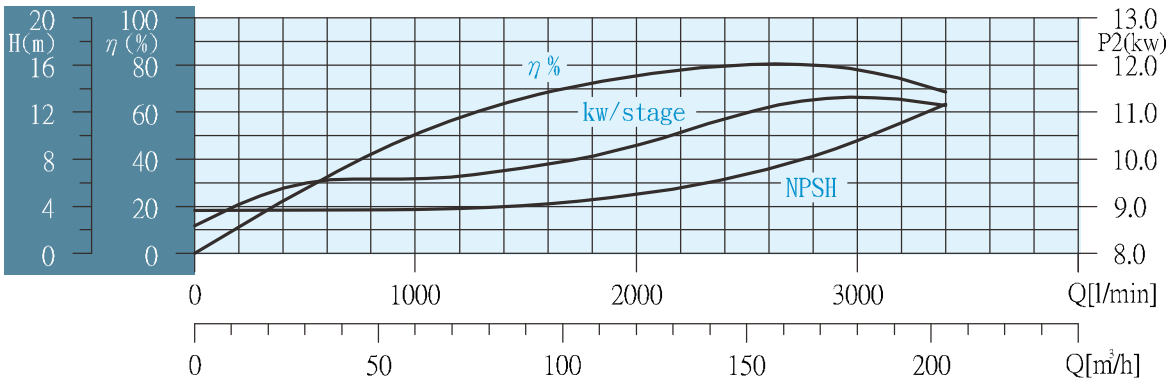
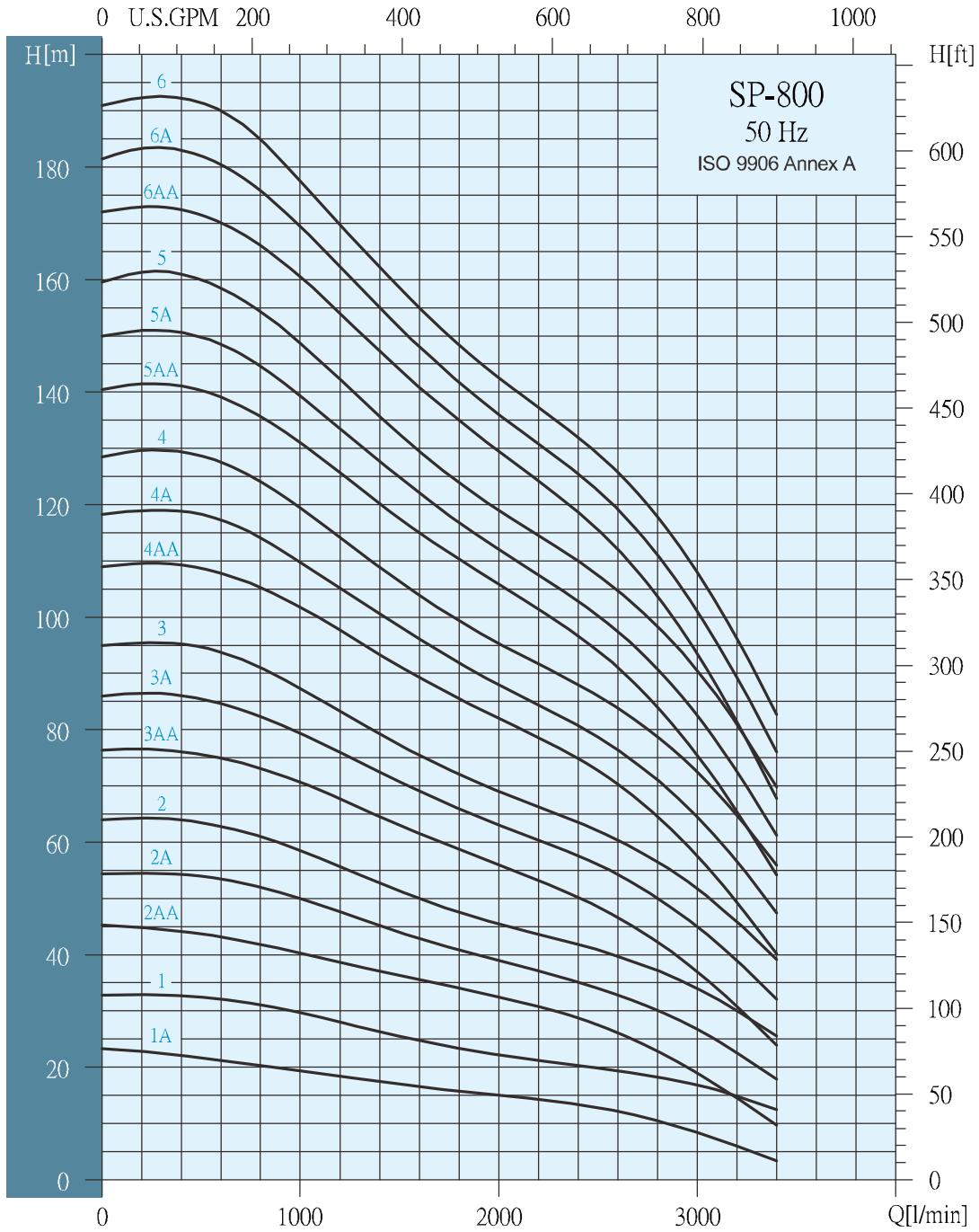



# Stairs SP Series

## 性能曲綫 SP800

SP10"

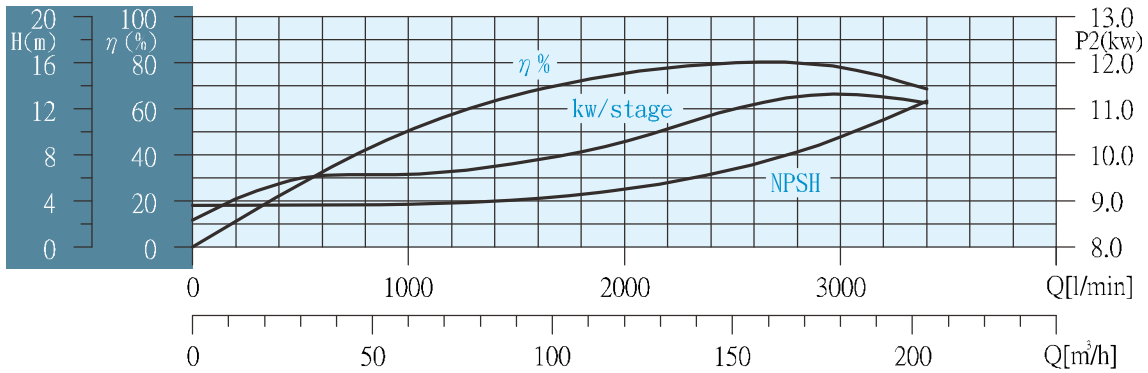
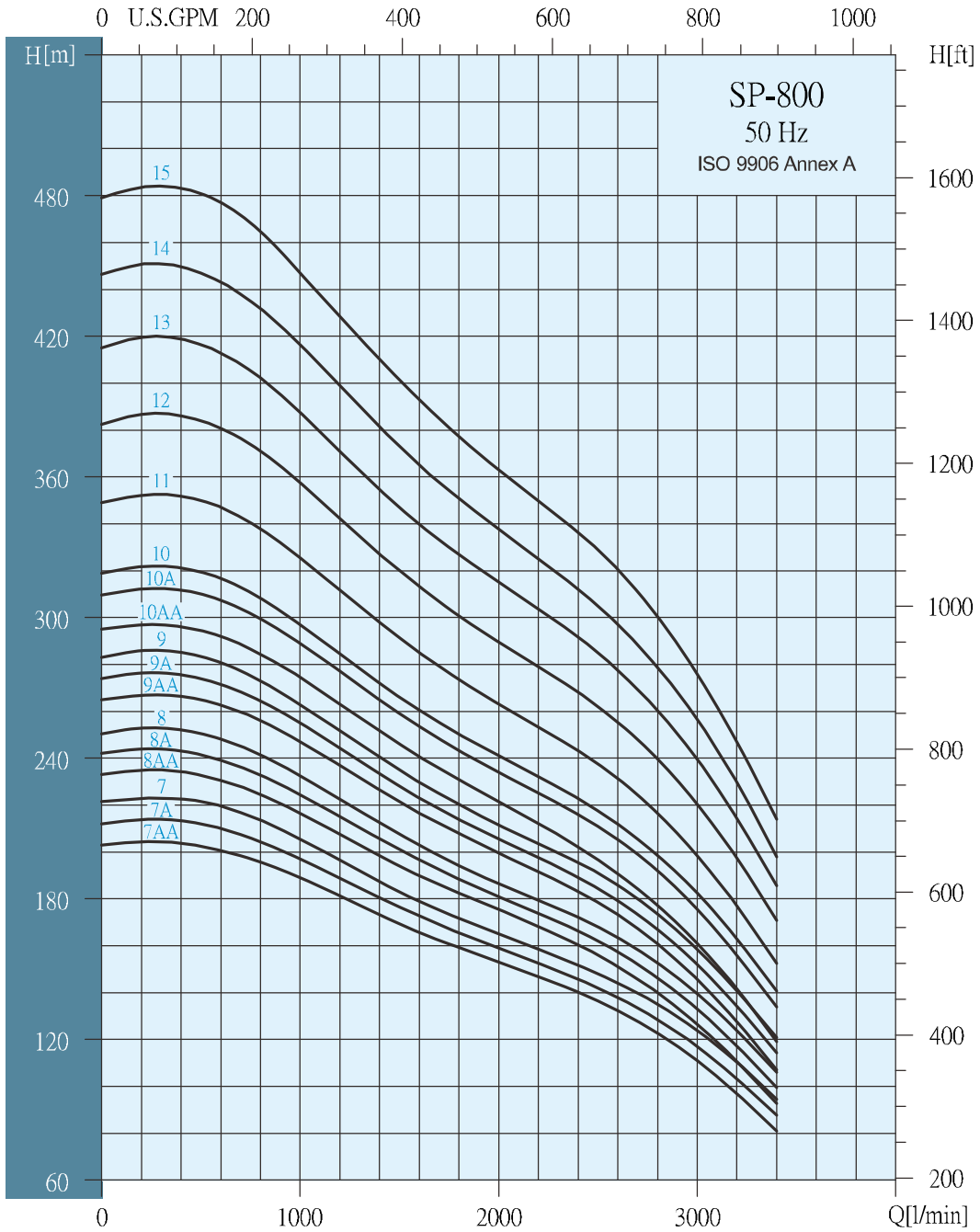



STAIRS PUMPS

# Stairs SP Series

SP800

SP10"

## 選型數據

Pump Type	Motor		Max.current		m³/h l/min	Q capacity 2900 rpm									
	P2		Amp			36	54	72	90	108	126	144	162	180	198
	KW	HP	220V	380V		600	900	1200	1500	1800	2100	2400	2700	3000	3300
SP 800-1-A	9.3	12.5	36	20.9	HEAD IN METERS	21	20	18	17	16	15	13	12	8	5
SP 800-1	13	17.5	50	29		32	31	28	25	24	22	20	19	17	14
SP 800-2-AA	18.5	25	69	40		43	41	39	36	34	32	29	25	19	12
SP 800-2-A	22	30	81	47		53	51	48	44	41	38	35	32	27	20
SP 800-2	26	35	96	56		63	60	56	51	48	45	42	38	34	28
SP 800-3-AA	30	40	111	64		75	72	68	63	59	55	50	45	37	28
SP 800-3-A	37	50	138	80		85	81	76	71	66	62	58	52	45	36
SP 800-3	37	50	138	80		94	89	83	78	72	68	64	59	52	43
SP 800-4-AA	45	60	154	89		108	104	98	91	85	80	75	68	57	45
SP 800-4-A	45	60	154	89		117	112	105	98	92	86	81	74	65	52
SP 800-4	55	75	192	111		128	122	114	106	99	94	88	81	73	61
SP 800-5-AA	55	75	192	111		139	134	126	118	110	104	97	88	75	60
SP 800-5-A	55	75	192	111		148	142	134	125	117	110	103	94	82	67
SP 800-5	63	85	240	139		158	152	142	132	124	117	110	102	90	76
SP 800-6-AA	63	85	240	139		170	163	154	144	135	127	119	108	93	75
SP 800-6-A	75	100	256	148	180	173	162	152	142	133	125	115	101	83	
SP 800-6	75	100	256	148	190	182	170	158	148	140	132	122	108	90	
SP 800-7-AA	75	100	256	148	200	193	181	169	159	150	140	128	111	89	
SP 800-7-A	93	125	335	194	210	201	188	177	166	156	146	134	117	96	
SP 800-7	93	125	335	194	220	210	196	183	172	162	152	140	124	102	
SP 800-8-AA	93	125	335	194	230	220	208	194	183	172	160	146	126	102	
SP 800-8-A	93	125	335	194	239	229	215	201	189	177	167	152	133	108	
SP 800-8	93	125	335	194	248	237	222	208	194	183	172	158	140	115	
SP 800-9-AA	110	150	390	226	263	252	237	222	208	196	183	167	146	117	
SP 800-9-A	110	150	390	226	272	260	244	228	214	202	189	174	152	124	
SP 800-9	110	150	390	226	281	268	252	235	220	207	196	180	159	131	
SP 800-10-AA	110	150	390	226	292	280	263	246	231	217	202	184	161	131	
SP 800-10-A	132	175			307	295	277	259	244	230	216	199	176	145	
SP 800-10	132	175			317	303	284	266	250	236	223	205	182	152	
SP 800-11	132	175			347	332	312	292	274	258	243	224	199	165	
SP 800-12	147	200			380	365	342	320	301	285	268	248	221	184	
SP 800-13	170	230			413	395	371	347	327	309	292	269	240	200	
SP 800-14	170	230			443	425	399	373	350	332	312	288	257	213	
SP 800-15	190	255			477	456	428	402	377	356	336	311	276	231	

## 尺寸和重量

Pump Type	motor Dia.	Dimensions(mm)						Net Weight(Kg)
		B6" Connection (RP,NPT)			B 6 " Flange			
		A	C*	C**	A	C*	C**	
SP 800-1-A	6"	652	211	218	652	222	226	30.4
SP 800-1	6"	652	211	218	652	222	226	30.4
SP 800-2-AA	6"	807	211	218	807	222	226	36.7
SP 800-2-A	6"	807	211	218	807	222	226	36.8
SP 800-2	6"	807	211	218	807	222	226	36.8
SP 800-3-AA	6"	963	211	218	963	222	226	43.2
SP 800-3-A	6"	963	211	218	963	222	226	43.2
SP 800-3	6"	963	211	218	963	222	226	43.2
SP 800-4-AA	8"	1118	218	227	1118	229	232	50.9
SP 800-4-A	8"	1118	218	227	1118	229	232	51.0
SP 800-4	8"	1118	218	227	1118	229	232	51.0
SP 800-5-AA	8"	1274	218	227	1274	229	232	57.3
SP 800-5-A	8"	1274	218	227	1274	229	232	57.4
SP 800-5	8"	1274	218	227	1274	229	232	57.4
SP 800-6-AA	8"	1429	218	227	1429	229	232	63.7
SP 800-6-A	8"	1429	218	227	1429	229	232	63.8
SP 800-6	8"	1429	218	227	1429	229	232	63.8
SP 800-7-AA	8"	1585	218	227				70.2
SP 800-7-A	8"	1585	218	227				70.2
SP 800-7	8"	1585	218	227				70.2
SP 800-8-AA	8"	1740	218	227				76.6
SP 800-8-A	8"	1740	218	227				76.7
SP 800-8	8"	1740	218	227				76.7
SP 800-9-AA	8"	1896	218	227				83.0
SP 800-9-A	8"	1896	218	227				83.1
SP 800-9	8"	1896	218	227				83.1
SP 800-10-AA	8"	2051	218	227				89.4
SP 800-10-A	10"	2181	227	247				102.6
SP 800-10	10"	2181	227	247				102.6
SP 800-11	10"	2337	227	247				109.0
SP 800-12	10"	2492	227	247				115.5
SP 800-13	10"	2648	227	247				121.9
SP 800-14	10"	2803	227	247				128.3
SP 800-15	12"							

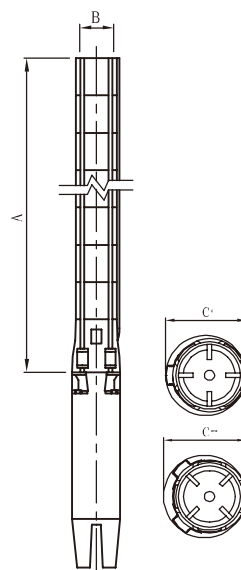

C\*: 泵的最大直徑包含1個纜護套  
 C\*\*: 泵的最大直徑包含2個纜護套



# Stairs SP Series

## 性能曲綫 SP1100

SP10"

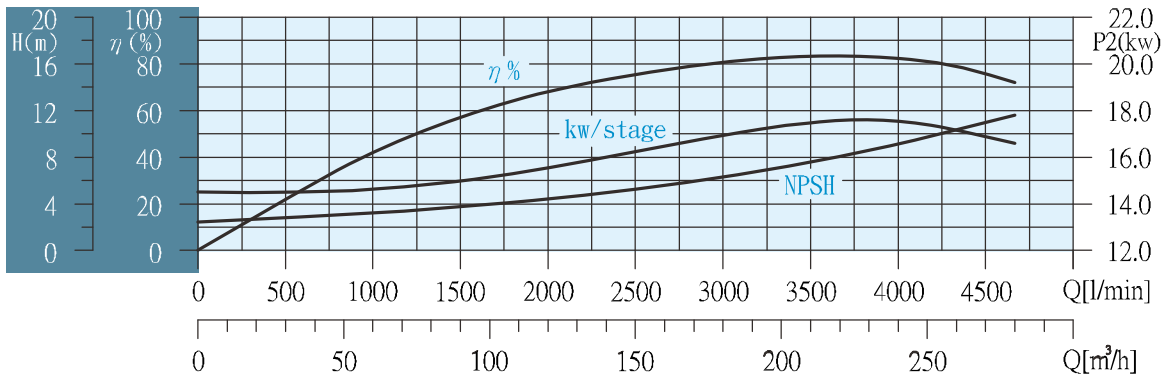
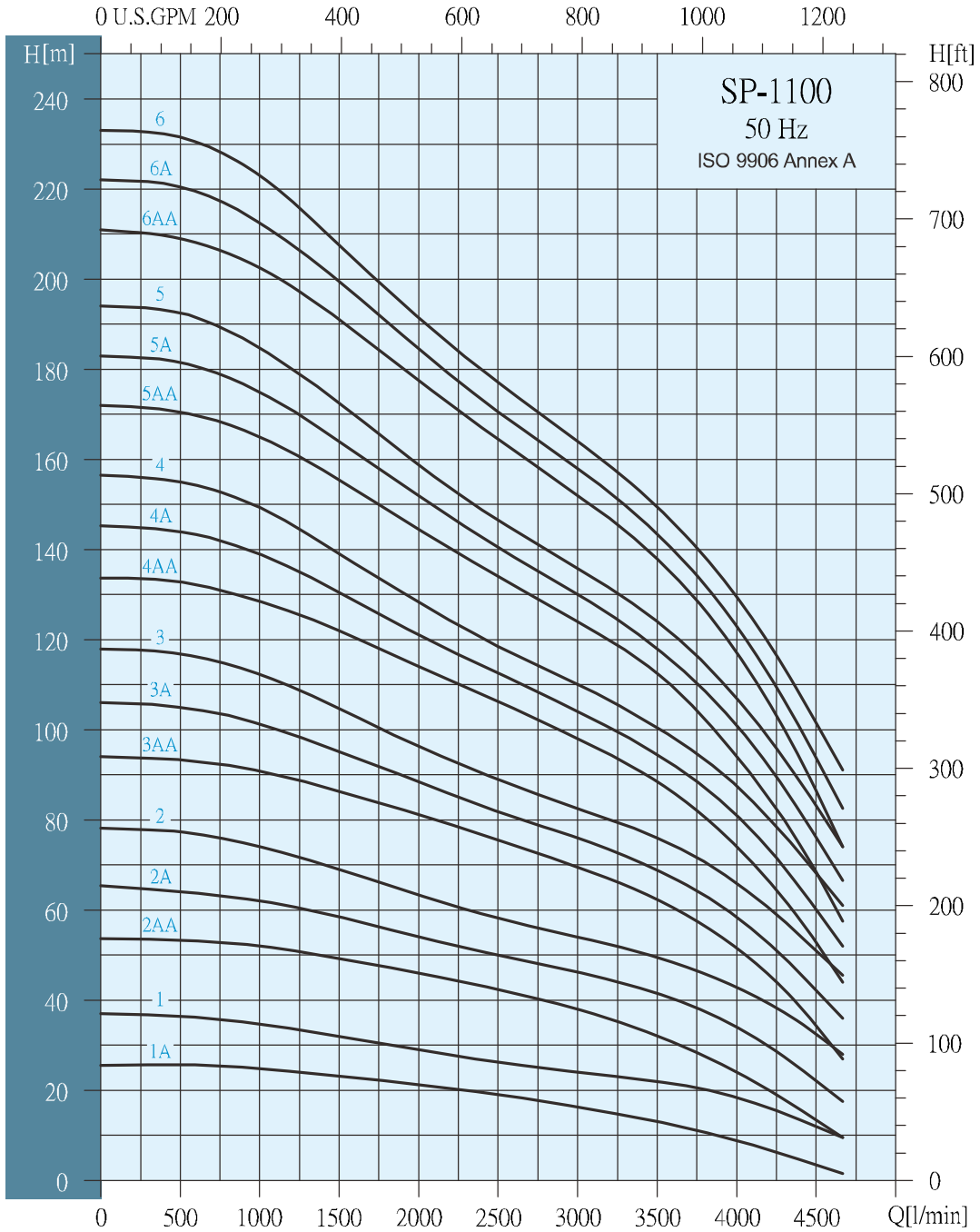



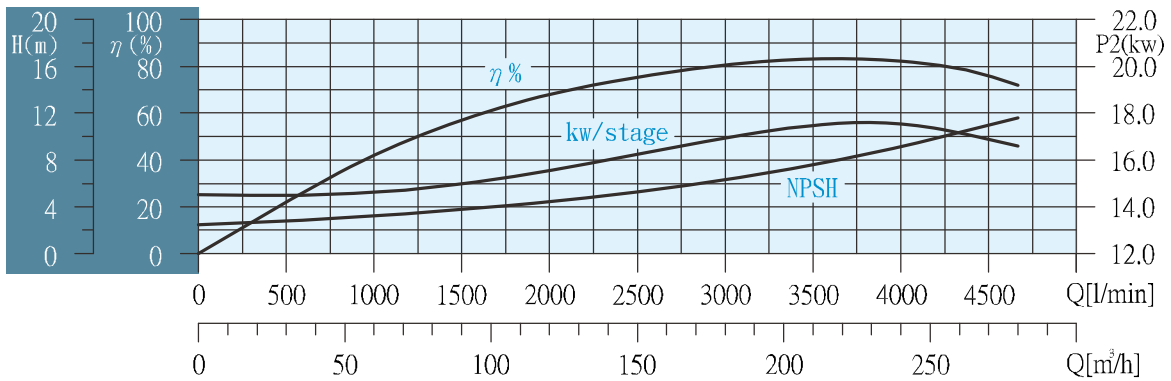
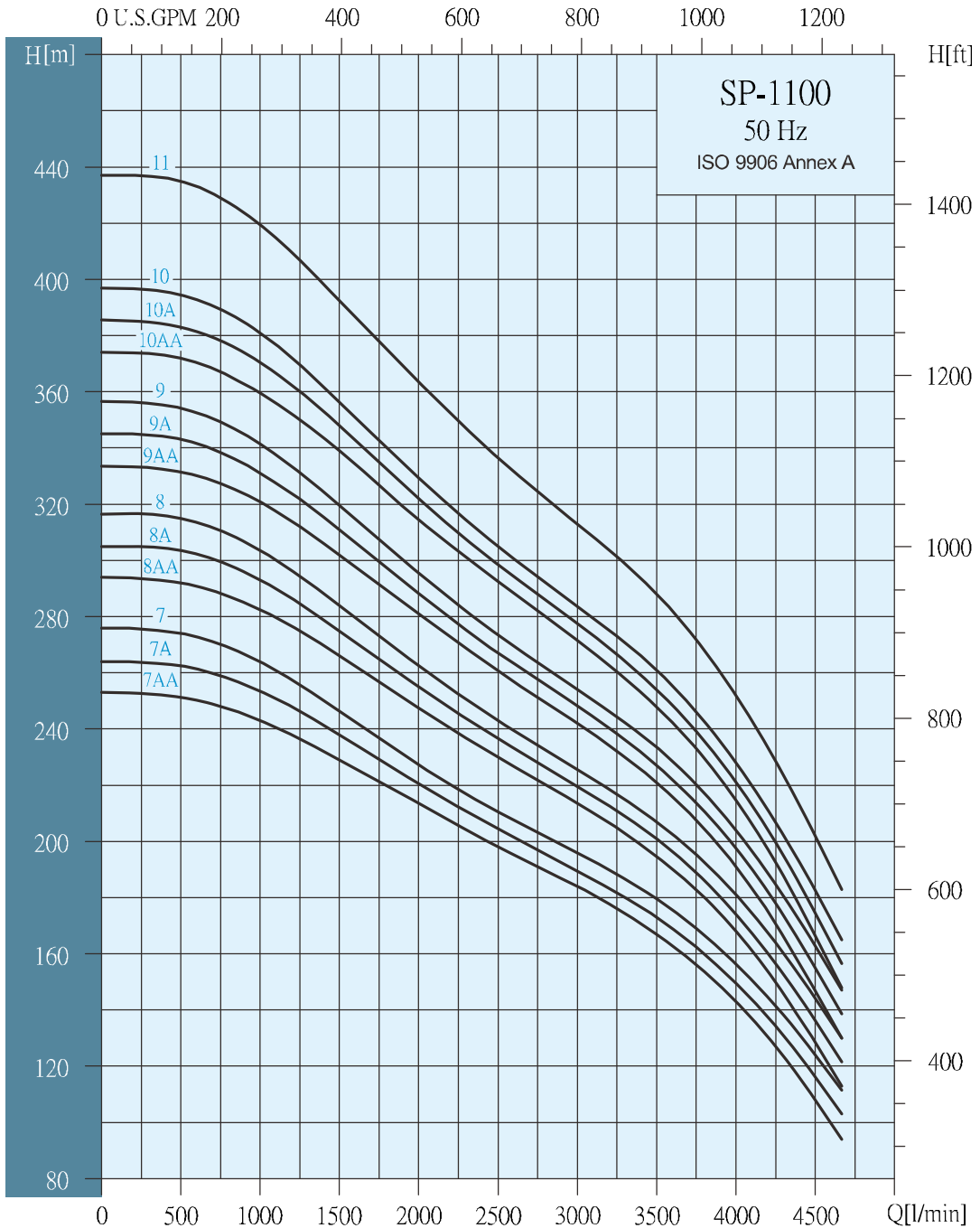



### 選型數據

Pump Type	Motor		Max.current		m³/h l/min	Q capacity 2900 rpm										
	P2		Amp			30	45	60	75	90	120	150	180	210	240	270
	KW	HP	220V	380V		500	750	1000	1250	1500	2000	2500	3000	3500	4000	4500
SP 1100-1-A	15	20	55	32	26	25.5	25	24	23	21	19	16	13	9	4	
SP 1100-1	18.5	25	69	40	36.5	36	35	33	32	29	26	24	22	18	12	
SP 1100-2-AA	30	40	111	64	53	52.5	52	50	49	46	42	38	32	24	14	
SP 1100-2-A	37	50	138	80	64	63	62	60	58	54	50	46	41	34	22	
SP 1100-2	45	60	154	89	77	76	74	71	69	63	58	54	49	42	32	
SP 1100-3-AA	55	75	192	111	93	92	90	88	86	81	75	69	62	51	34	
SP 1100-3-A	55	75	192	111	105	103	101	98	95	88	82	76	69	58	42	
SP 1100-3	63	85	240	139	117	115	112	108	104	96	89	82	76	66	51	
SP 1100-4-AA	75	100	256	148	133	131	128	125	122	114	106	98	88	74	53	
SP 1100-4-A	75	100	256	148	144	142	139	135	130	121	112	104	94	81	60	
SP 1100-4	75	100	256	148	155	152	149	144	139	128	118	110	100	87	68	
SP 1100-5-AA	93	125	335	194	170	168	165	160	155	144	134	124	112	94	68	
SP 1100-5-A	93	125	335	194	181	179	175	170	164	152	140	130	118	101	76	
SP 1100-5	93	125	335	194	192	189	184	179	172	159	146	135	124	107	83	
SP 1100-6-AA	110	150	390	226	209	206	202	197	191	178	164	152	138	117	86	
SP 1100-6-A	110	150	390	226	220	217	212	206	199	184	170	158	143	123	93	
SP 1100-6	110	150	390	226	231	228	223	216	207	191	177	164	149	129	101	
SP 1100-7-AA	132	175			251	248	243	236	229	213	198	184	167	143	108	
SP 1100-7-A	132	175			262	259	253	246	238	220	204	189	173	149	116	
SP 1100-7	132	175			274	270	264	255	246	227	210	196	180	156	124	
SP 1100-8-AA	147	200			292	288	282	274	266	247	230	213	195	168	128	
SP 1100-8-A	147	200			303	299	293	284	275	255	236	219	201	174	136	
SP 1100-8	147	200			315	310	303	294	284	262	243	225	207	181	144	
SP 1100-9-AA	170	230			331	327	320	312	302	281	260	242	221	191	146	
SP 1100-9-A	170	230			343	338	331	321	311	288	267	248	227	197	155	
SP 1100-9	170	230			354	349	341	331	319	295	273	254	233	204	162	
SP 1100-10-AA	190	255			372	367	359	350	339	314	292	271	248	214	166	
SP 1100-10-A	190	255			383	378	370	360	347	322	296	277	254	221	174	
SP 1100-10	190	255			394	389	381	369	356	329	305	283	261	228	182	
SP 1100-11	220				435	429	419	407	392	363	336	313	288	252	201	

HEAD IN METERS

### 尺寸和重量

Pump Type	motor Dia.	Dimensions(mm)			Net Weight(Kg)
		B6" Connection (RP,NPT)			
		A	C*	C**	
SP 1100-1-A	6"	771.7	237	241	46.1
SP 1100-1	6"	771.7	237	241	46.1
SP 1100-2-AA	6"	947.7	237	241	56.1
SP 1100-2-A	6"	947.7	237	241	56.1
SP 1100-2	8"	947.7	237	241	55.8
SP 1100-3-AA	8"	1123.7	237	241	65.6
SP 1100-3-A	8"	1123.7	237	241	65.6
SP 1100-3	8"	1123.7	237	241	65.6
SP 1100-4-AA	8"	1299.7	237	241	75.4
SP 1100-4-A	8"	1299.7	237	241	75.4
SP 1100-4	8"	1299.7	237	241	75.4
SP 1100-5-AA	8"	1475.7	237	241	85.8
SP 1100-5-A	8"	1475.7	237	241	85.8
SP 1100-5	8"	1475.7	237	241	85.8
SP 1100-6-AA	8"	1651.7	237	241	96.2
SP 1100-6-A	8"	1651.7	237	241	96.2
SP 1100-6	8"	1651.7	237	241	96.2
SP 1100-7-AA	10"	1827.7	262	274	111.2
SP 1100-7-A	10"	1827.7	262	274	111.2
SP 1100-7	10"	1827.7	262	274	111.2
SP 1100-8-AA	10"	2003.7	262	274	121.5
SP 1100-8-A	10"	2003.7	262	274	121.5
SP 1100-8	10"	2003.7	262	274	121.5
SP 1100-9-AA	10"	2179.7	262	274	131.7
SP 1100-9-A	10"	2179.7	262	274	131.7
SP 1100-9	10"	2179.7	262	274	131.7
SP 1100-10-AA	12"				
SP 1100-10-A	12"				
SP 1100-10	12"				
SP 1100-11	12"				

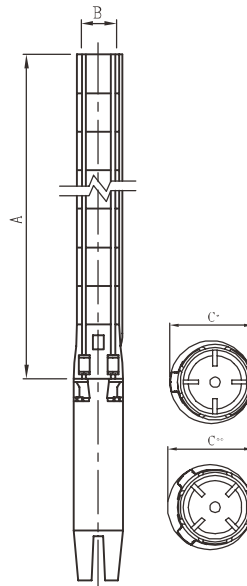

C\*:泵的最大直徑包含1個綫纜護套  
C:\*\*泵的最大直徑包含2個綫纜護套





天津鴻新益發科技有限公司

地址：天津市華苑產業園區華天道8號  
海泰信息廣場C座1011

電話：+86 ( 22 ) 58113062

傳真：+86 ( 22 ) 58113042

網址：[www.e-hxyf.com](http://www.e-hxyf.com)