



SPC 系列 冷卻泵

50HZ/60HZ



STAIRS INDUSTRIAL CO., LTD.

應用範圍

SPC冷卻泵是同軸設計可應用裝置於銑、車、磨、切割各種工具機，適用於循環冷卻液，輕質油及各種非腐蝕性液體。

泵的結構

該泵是單段直立式離心泵，同軸泵/電機設計，葉輪安裝在電機的加長軸心上。

型號代碼

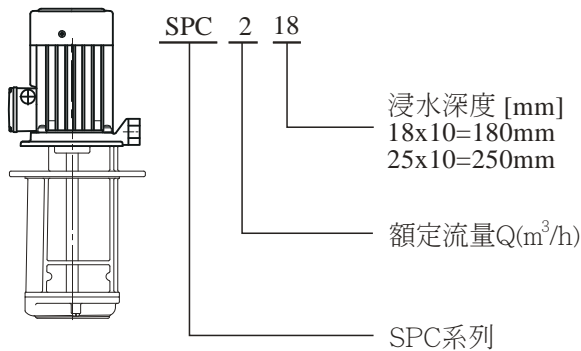

安裝條件

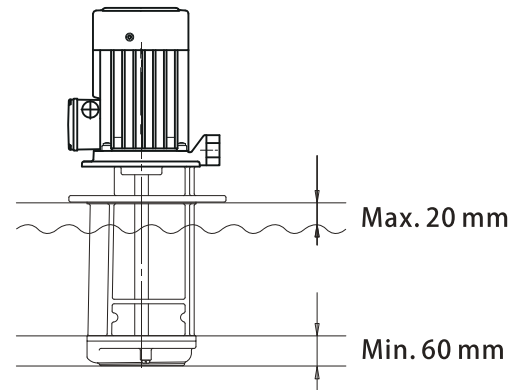

馬達

頻率:50 / 60 Hz

絕緣等級:F class

防塵防水等級:IP 54

額定轉速:2900 / 3500 RPM

標準電壓:3Ø 50Hz:220-240V / 380-415V
3Ø 60Hz:220-255V / 380-440V

運行條件

液體溫度範圍:+0°C ~ +90°C

環境溫度:Max. +40°C

工作壓力:Max. 10kg/cm²

液體黏稠度:1~32 cSt

Power: 50Hz:170W~770W
60Hz:305W~1160W

50Hz:Head Up to 12M

Flow Up to 245 L/min

60Hz:Head Up to 16.5M

Flow Up to 290 L/min

Outlet:1/2"~1"

性能曲線

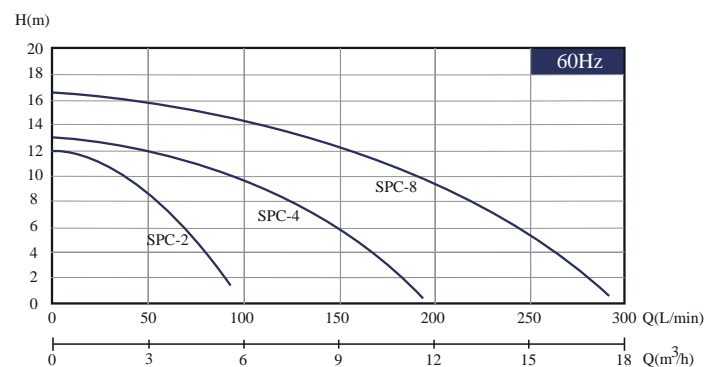
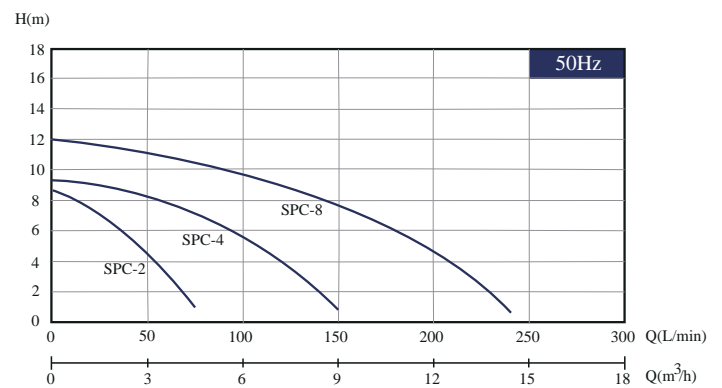

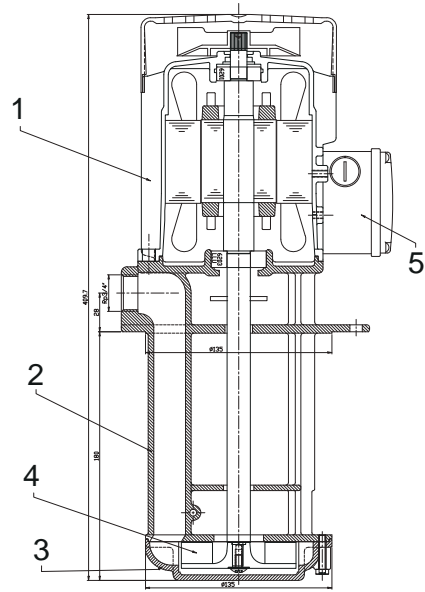
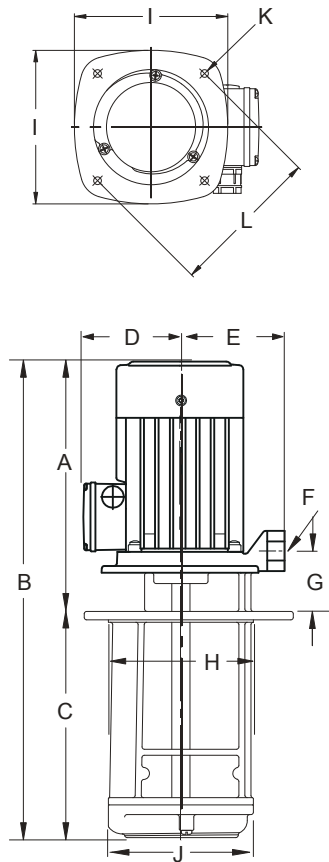
外型

No.	零件	材質
1	馬達	ADC12
2	泵體	FC200
3	泵蓋	FC200
4	葉輪	NYLON
5	接線盒	ABS

型號	尺寸 (mm)												重量 (kg)	一棧板台數 	棧板尺寸 L x W x H (cm)
	A	B	C	D	E	F	G	H	I	J	K	L			
SPC 2-18	185	365	180	115	85	RP1/2"	21	110	160	120	4*ø8	PCD 158	9.5	50	100 x 100 x 167
SPC 2-25	185	435	250	115	85	RP1/2"	21	110	160	120	4*ø8	PCD 158	10.5		100 x 100 x 167
SPC 4-18	225	405	180	115	90	RP3/4"	25	120	170	135	4*ø8	PCD 170	11		110 x 110 x 167
SPC 4-25	225	475	250	115	90	RP3/4"	25	120	170	135	4*ø8	PCD 170	12		110 x 110 x 167
SPC 8-18	270	450	180	115	95	RP1"	30	130	190	150	4*ø8	PCD 185	14		105 x 110 x 123
SPC 8-25	270	520	250	115	95	RP1"	30	130	190	150	4*ø8	PCD 185	15.2		95 x 110 x 123

產品規格

型號	相數	輸入 瓦特	頻率	出水口	揚程 (M)	水量 (L/min)	電壓		滿載電流	
		(W)		(inch)			50HZ	60HZ	50HZ	60HZ
SPC 2-18	3ø	170/305	50/60	1/2"	8.5 / 12	75/90	220~240/380~415V	220~255/380~440V	0.8-0.9/0.49-0.53	0.9-1.0/0.5-0.55
SPC 2-25		1/2"								
SPC 4-18		405/650		3/4"	9 / 13	150/190	220~240/380~415V	220~255/380~440V	1.5-1.6/0.8-1.0	1.9-2.1/1.0-1.1
SPC 4-25		405/650		3/4"						
SPC 8-18		770/1160		1"	12 / 16.5	240/290	220~240/380~415V	220~255/380~440V	2.9-3.0/1.7-1.9	3.4-3.5/1.9-2.1
SPC 8-25		770/1160		1"						



STAIRS

www.stairs.com.tw

